

COMBI OVEN | USER MANUAL



Please read the instructions before installing and using the appliance. Translation of the original instructions.

Installation, Use & Maintenance

Dear customer

Congratulations on the purchase of your new Combination Oven. By purchasing this new oven, you have entered into a new era of cooking. With the new technology and simplicity built into the Combination Oven, you will receive excellent results in no time at all. The oven's ease and simplicity of operation will help you realize savings in training dollars.

With the one touch, simply identify the relevant food, push start, and you are cooking. The simplicity of operation guarantees consistently produced products without having to set times, temperatures, and finishes.

For the Chef, the Combination Oven offers a wide array of functions and steps that once tested can be saved and recreated by experienced kitchen staff as well as the first time operator.

Appliance Model _____

S/N _____

Dealer _____

Installer _____

Date of install _____

NOTICE

Please read the operations manual in full before starting up the appliance to make sure all the benefits and safety information is understood.

Installation, Use & Maintenance

Table of contents

Introduction	6
Intended use	
Safety information	9
Safety precautions	
Safe work practices	
Specific precautions	
General safety guidelines for installers, users, and service technicians	
Health and sanitation practices	10
Pre-installation checklist	11
Ventilation requirements	12
Water quality	13
Installation	14
General information	
Unpacking and handling	
Required clearances/positioning	15
Door adjustment	16
Electrical connection	17
Water connection	18
Drain connection	19
Product registration/installation checklist	20
Cooking	23
Home Screen	25
How to interact with the touch-screen	25
Cooking modes: Convection, mixed and steam	27
Hold Mode	29
Smoking mode	29

Installation, Use & Maintenance

Table of contents	
Starting and stopping cooking	30
Customized cooking programs	30
Creating a cooking program	31
Saving a cooking program	32
Modifying a cooking program	33
Copy,move, rename and delete	33
Selecting a program from the menu	34
The RecipeTuner interfaces	35
Multitimer service mode	36
Using the Multitimer function	36
Creating a new Multitimer program	37
Using the EasyService function in Multitimer	40
Programmed start	41
The core probe and cooking in	41
Recommendations for cooking: roasting, grilling and frying	42
Cooking advice: cooking uniformity	42
Cooking recommendations: vacuum cooking and pasteurisation	42
Functions menu	43
Washing (if envisaged)	43
Cooling	43
Service	45
Configuration	46
Date and time	46
Info system	46
Language	46

Installation, Use & Maintenance

Table of contents

Lighting	46
Buzzer volume	46
Log display	47
Advanced services	47
Import/export	47
Maintenance and cleaning	48
Cleaning the ventilation filter	48
Humidity discharge	49
Cleaning the glass	49
Management of spare parts	49
Alarms description	50
Technical data sheets	51

Installation, Use & Maintenance

Introduction/safety information

Intended Use:

Combination Ovens are solely intended for use in commercial kitchens.

The units may only be used for cooking food using the correct racks, containers, baking sheets, and slide in pans. Roll in rack dollies and cassettes must only be supplied by .

Units should only be used with highest quality drinking water for unit protection. The owner of the oven should test water for filtration needs. Water quality needs can be found in the manual under "Water Quality."

Your new oven should not be used for the following purposes, among others:

- As a dishwasher
- Drying towels, paper, or dishes
- As a storage container
- Heating brines, oils, or other chemicals
- Heating closed containers (i.e. canned goods)
- Heating flammable liquids
- Deep frying
- Cleaning air filters or equipment parts



Safety precautions Always follow recommended safety precautions listed in this manual. To the left is the safety alert symbol. When you see this symbol on your equipment, be alert to the potential for personal injury or property damage.

Safety Signs and Messages

The following safety signs and messages are placed in this manual to provide instructions and identify specific areas where potential hazards exist and special precautions should be taken. Know and understand the meaning of these instructions, signs, and messages.

⚠ DANGER

This message indicates an imminent hazardous situation which, if not avoided, will result in death or serious injury.

⚠ WARNING

This message indicates a potentially hazardous situation, which, if not avoided, could result in death or serious injury.

⚠ CAUTION

This message indicates a potentially hazardous situation, which, if not avoided, may result in minor or moderate injury. It may also be used to alert against unsafe practices.

NOTICE

This message is used when special information, instructions or identification are required relating to procedures, equipment, tools, capacities and other special data.

⚠ WARNING

California Residents Only
WARNING: This product can expose you to chemicals including chromium which is known to the State of California to cause cancer and birth defects or other reproductive harm. For more information go to www.P65Warnings.ca.gov.

Safety information-safe work practices

Beware of High Voltage

This equipment uses high voltage. Serious injury can occur if you or any untrained or unauthorized person installs, services, or repairs this equipment. ALWAYS use an AUTHORIZED SERVICE AGENT to service your equipment.



Beware of Hot Surfaces—DO NOT Touch

The door on this unit reaches temperatures that can cause burns. Use caution when opening and closing the door. Do not touch any of the surfaces when the unit is heated.



Protect Children

Keep children away from this equipment. Children may not understand that this equipment is dangerous for them and others.



NEVER allow children to play near or operate your equipment.

Be Prepared for Emergencies

Be prepared for fires, injuries, or other emergencies.

Keep a first aid kit and a fire extinguisher near the equipment. You must use a 40-pound type BC fire extinguisher and keep it within 25 feet of your equipment. Keep emergency numbers for doctors, ambulance services, hospitals, and the fire department near your telephone.



Know Your Responsibilities as an Employer

• Make certain your employees know how to operate the equipment.

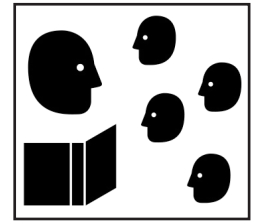

• Make certain your employees are aware of the safety precautions on the equipment and in this manual.

• Make certain that you have thoroughly trained your employees about operating the equipment safely.

• Make certain the equipment is in proper working condition. If you make unauthorized modifications to the equipment, you will reduce the function and safety of the equipment as well as void the warranty.

Keep this Manual With the Equipment

This manual is an important part of your equipment.

Always keep it nearby for easy access.

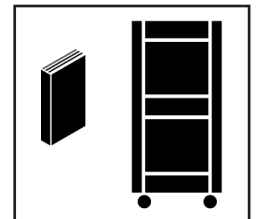

If you need to replace this manual, contact:

The Legacy Companies
101 East McBee Avenue
Greenville, South Carolina 29601
1-833-446-7451

Installation, Use & Maintenance

Safety information-specific precautions

⚠ CAUTION

Equipotential Ground Plane

When a high current flows through a conductor, differences in potential appear between the conductor and nearby metallic surfaces near the appliance. As a result, sparks may be produced between the appliance and surrounding metal surfaces. These sparks could cause serious injury, damage, or fire.



provides an Equipotential ground terminal for the connection of a bonding conductor after the installation of the appliance per IEC60417-1. This terminal is located on the inside of the Power Entry Supply box near the Earth connection and is marked with this symbol.

⚠ WARNING

Disconnect power before servicing.

⚠ WARNING

Improper installation, adjustment, alteration, service, or maintenance can cause property damage, injury, or death. Read the installation, operating and maintenance instructions thoroughly before installing or servicing this equipment.

⚠ WARNING

DO NOT connect Combination Oven drain connection to any drain material that cannot sustain 175°F.

NOTICE

For Your Safety

DO NOT store or use gasoline or other flammable vapors or liquids in the vicinity of this or any other appliance.

NOTICE

For Your Safety

All service must be performed by a qualified & authorized technician.

NOTICE

For Your Safety

This manual is a part of your new oven. You must keep and maintain it for the entire life span of your oven and pass it on to the next owner of the unit.

Retain this manual for reference, keep it where you can use it.

This manual may be subject to new technical developments, modifications, and unforeseen errors.

DO NOT operate or attempt to operate this appliance or any accessories without reading completely and fully understanding this manual.

Safety information

General Safety Guidelines for Installers, Users, and Service Technicians

- Read, understand, and follow the instructions, heed and obey the warnings of the Installation manual, the Operator's Manual, and the labels on the oven, accessories, and supporting products.
- Improper installation, maintenance, cleaning, or modifications to the oven can lead to injury or death of the operator(s), and equipment and property damage.
- **Steam** – To avoid steam burns, open the Combination Oven door by turning the handle to the left or clockwise ("airing") position and waiting for the steam and condensate to clear. Then, turn to the right or counterclockwise and slowly open the door. Never breathe steam, superheated steam, or hot air. NOTE: The cooking program is interrupted whenever the door is opened.
- **Heat** – The Combination Oven, cooking containers, shelves, and inner door and anything else inside the cooking compartment are HOT, as are many of the component parts. Wear DRY heat-proof gloves or mitts.
- **Exhaust Vents** – The top of the Combination Oven, and the gas and steam exhaust vents are very hot during operation and remain hot for some time. Never breathe gas or steam from the exhaust vents. Use extreme caution when working on or near this area and component parts.
- **Scalds** – **DO NOT** place containers with liquid contents or contents that become liquid on oven racks higher than you can see. You must be able to see into the container. Cover containers (individual or on trolleys) containing hot or hot liquid items to help prevent spills during transport. Observe and heed, & obey the additional warning labels posted on the oven.
- **Grease Spatter** – Hot grease will spatter and cause burns if sprayed with water. Locate fryers and similar appliances outside the range of the Combination Oven hand shower.
- **Electric Shock** – Use the hand shower only on the inside of the oven. Use of the hand shower, hoses, power cleaners, or pressure washers on the outside of the oven can cause electric shock and/or damage to electrical and electronic components.
- **Cleaning and Daily Maintenance**
Wait for the oven to cool before cleaning and performing daily maintenance. DO NOT spray water in a hot cooking compartment. Do not use hoses, power cleaners, pressure washers, or harsh or abrasive cleaning agents inside OR outside the cooking compartment.
- **Cleaning Agents** – Use only approved cleaning and descaling products. Follow the instructions and heed & obey the warnings on the labels. Other products can damage the oven, cause injury, or present health hazards.
- Wear appropriate shoes/boots to the work area to help protect feet and to help prevent slips and falls.
- Use non-slip, draining, anti-fatigue FLOOR MATS (not included) rated for use in wet, greasy, and dry work areas to help prevent slipping and/or falling injuries. Obtain the best mats for your needs from your local supplier.

Health and sanitation practices

Combination Ovens are manufactured to comply with health regulations and are tested and certified to UL®, cUL®, and NSF® standards. You must operate the equipment properly using only quality products and use meat thermometers to insure meats are thoroughly cooked.

Food Handling

- Wash hands thoroughly in warm, soapy water after handling raw poultry or meats.
- Clean and sanitize all utensils and surfaces that have been in contact with raw products. Clean and sanitize the meat forks or baskets between cooking.
- Never place cooked meats on the same surfaces used to prepare raw meats, unless the area has been thoroughly cleaned and sanitized.

Storage of Raw Meats

- Designate an area or shelf strictly for the storage of all raw meats to be used in the oven.
- Raw product must always be stored at temperatures below 38° F.
- Never store or mix raw foods above cooked foods, as **this is a health hazard**. The drippings from raw foods contaminate cooked or processed foods.
- All chicken and chicken parts to be stored overnight must be thoroughly iced down and refrigerated.

Coding Cooked Foods

- All products cooked during the day should be sold the same day.

NOTE: Follow your company's procedures for the handling of any leftover product.

Storage of Prepared Foods

- Cold foods should be kept at or below 38° F
- Hot foods must be maintained to meet local health codes, usually a minimum 145° F

COMBI OVEN PRE-INSTALLATION CHECKLIST

Proposed Model #: _____

Proposed Gas Type (NG or LP): _____

Proposed Machine Voltage & Phase: _____

Proposed name of installer: _____

Company Name/Address: _____

Required date of Installation: _____

End Customer Name, Title and Date: _____

- 1) Verify ventilation requirements. Will installation use an existing or ventless hood? _____
- 2) Verify ventilation height and width. What is clearance to bottom of hood? _____
What is the width of the hood (front to back)? _____
- 3) Verify ventilation location. Is the hood against a wall or an island hood? _____
- 4) Verify oven's proposed location is level and adequate spacing is provided on all sides per instruction manual. If a heat source (fryer, cooktop, etc) would next to combi oven machine compartment, verify heat shields are quoted.
- 5) Verify drain (minimum temperature requirement of 175F. NO PVC) is accessible for proposed oven, not located under the proposed oven location and within reasonable distance from the oven. For stacked ovens, drain must be in the floor.
- 6) Verify Electrical Supply Voltage, Amperage and Phase are operational and available within 10 feet of proposed oven location.
- 7) If a gas oven is required, verify gas supply connections, pressure and volume capacity for static and dynamic operation.
- 8) Verify cold water supply to the oven is 35-60 PSI (flowing) and there are proper connections for oven/s.
- 9) Verify water treatment. Type (Filter, Water Softener, RO) _____, Brand _____ . Provide pictures
- 10) Verify the water supply chemical concentrations before water treatment: _____ Hardness, _____ TDS, _____ pH, _____ Chlorides. Provide pictures.
- 11) Verify the water supply chemical concentrations into oven are within specifications: _____ Hardness (30 to 90 ppm), _____ TDS (40 to 150 ppm), _____ pH (7.0 to 8.5), _____ Chlorides (below 20 ppm). Please note out of specification values. Provide pictures.
- 12) Verify what detergent (tablets or liquid) will be in operation. If liquid will be used, please specify. _____ . Provide pictures

Date: _____

Representative Signature _____

Installation, Use & Maintenance

Ventilation requirements

Some local codes may require the Combination Oven to be located under an exhaust hood.

Information on the construction and installation of ventilating hoods may be obtained from Vapor Removal from Cooking Equipment, NFPA Standard No. 96 (latest edition).

NOTE: all hood and ducting of ovens must comply to local codes interpreted by fire and building inspectors in the municipality where the oven is installed.

Ventilation hoods must ensure an adequate amount of incoming air during operation and must be operated whenever the Combination Oven is used in order to avoid the accumulation of condensation in the hood area.

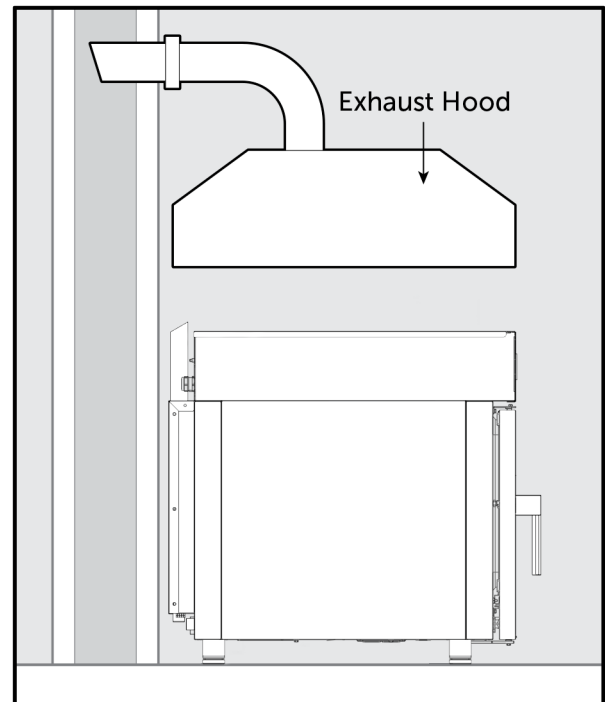

Water quality

As with all steam related products, water filtration and regular filter replacements may be necessary with the Combination Oven. It is strongly recommended to have a water analysis performed prior to installing the Combination Oven. Poor water quality can have a big impact on cook quality, performance, and longevity of the Combination Oven. Varying combinations of pH; alkalinity; hardness; chlorides; total dissolved solids; and other chemical characteristics, when subjected to high temperatures, will cause water to have a tendency to either scale or corrode.

There are a number of different water filter/ treatment systems available and each has its own benefits and specialties. Below are a different styles and their benefits. Multiple styles may need to be used to get the water to proper levels.

• Particle Filter

When the water contains sand, iron particles, or suspended matter, we recommend a 5-15 μm (micrometer) particle filter.

• Active Carbon Filter

When the level of chlorine (Cl) in the water exceeds 0.5 mg/L (ppm) (information available from the water company), an active carbon filter should be installed.

• Phosphate Additive System

A Phosphate Additive (Feeder) System is recommended for steam generator units only when a moderate level of scale (not containing chloride) is experienced.

• Ion Exchange System

An ion exchange system is recommended for a steam generator based unit when a high level of scale (not containing chloride) is experienced and for a spritzer based unit when any scale (not containing chloride) is experienced. Sodium ion exchangers (as used in dishwashers) must not be used.

• Blended Reverse Osmosis (RO)

When the water has a chloride (Cl) concentration above 20 mg/L (= 20 ppm), a blended RO system should be installed to avoid corrosion.

NOTE: Make sure a minimum conductivity of 20 $\mu\text{S}/\text{cm}$ (microSiemens) remains in the water for steam generator units.

Water quality must conform to the below requirements. If water does not meet the minimum quality and damage to the oven is determined to be due to water quality, it will be considered non warranty and will not be covered under the stated warranty policy.

Minimum Water Quality Requirements

- Hardness (CaCO_3) = 30 to 90 mg/L (Milligrams per Liter)
- TDS (Total Dissolved Solids) = 40 to 150 mg/L (Milligrams per Liter)
- Free Chlorine = Less than 0.1 mg/L (Milligrams per Liter)
- Chlorides = Less than 20 mg/L (Milligrams per Liter)
- Chloramines = Less than 0.5 mg/L (Milligrams per Liter)
- Sulfates & Nitrates = Less than 20 mg/L (Milligrams per Liter)
- Total Silica = Less than 10 mg/L (Milligrams per Liter)
- Total Iron = Less than 0.1 mg/L (Milligrams per Liter)
- pH level = 7.0 to 8.5
- Langelier Index = Greater than 0.5

Installation

General information

⚠ WARNING

Serious injury, equipment damage or death could result if attempting to install this oven yourself. Ensure that an authorized service agent installs the Combination Oven.

Only qualified, professional plumbers, pipe fitters, and electricians should install this equipment.

• The installation of this Combination Oven must conform with:

- The Basic Plumbing Code of the Building Officials and Code Administrators International, Inc. (BOCA).
- The National Electrical Code, ANSI/NFPA 70 (latest edition), or the Canadian Electrical Code, CSA C22.2 as applicable.
- The Food Service Sanitation Manual of the Food and Drug Administration (FDA).
- All applicable national, state, and local laws, codes, and regulations.

⚠ WARNING

Death, injury, and equipment damage can result from improper lifting. Use adequate workers with training and experience lifting heavy equipment to place the oven on the supporting surface.

Unpacking and Handling

It is the owners' responsibility to file all freight claims with the delivering truck line. Inspect all cartons and crates for damage as soon as they arrive. If damage to cartons or crates is found, or if a shortage is found, note this on the bill of lading (all copies) prior to signing.

If damage is found when the equipment is opened, immediately call the delivering truck line and follow up the call with a written report indicating concealed damage to your shipment. Ask for an immediate inspection of your concealed damage item. Packaging material **MUST** be retained to show the inspector from the truck line.

Remove all packing from the interior and exterior of the oven.

Installation, Use & Maintenance

Installation

Required Clearances

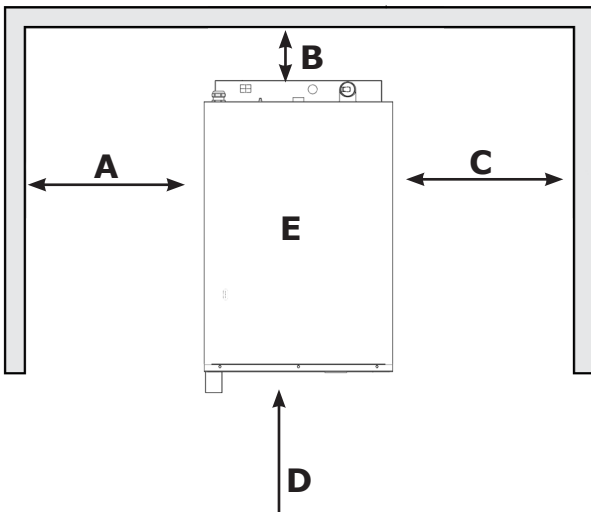

- A.** Left Side 3"
- B.** Rear – 3" (utilities)
- C.** Right Side – 3"
- D.** Door
- E.** Top (Servicability)

– If next to a high heat source (i.e. fryer or broiler), ensure that there is adequate distance or a heat shield is installed.

Positioning

Follow the criteria below when selecting a location for your Combination Oven:

- Ensure the oven will go through any doorways or passages (see Shipping Weights and Dimensions table below).
- If oven is going on a counter top or stand not supplied by , ensure the supporting structure can hold the weight of the oven fully loaded with food (see Shipping Weights and Dimensions table below).
- The floor/stand must be level to ensure proper door sealing and operation.
- The position of the oven should be that the oven will not slide or tip.
- The area around the oven should be free from combustibles.
- The ambient temperature should be within 40° F to 95° F.
- Ensure the oven air vents are not blocked.

NOTE: Do not install the Combination Oven over a drain. Rising steam out of the drain can have adverse affects on operation, impede cooling air circulation, and damage electrical and electronic components.

Shipping weight & dimensions

	Weight Lbs (Kg)	Width in (mm)	Depth in (mm)	Height in (mm)
061 model	202 (92)	22.83 (580)	38.58 (980)	46.26 (1175)

	Weight Lbs (Kg)	Width in (mm)	Depth in (mm)	Height in (mm)
101 model	242 (110)	22.83 (580)	38.58 (980)	46.26 (1175)

Installation-Positioning/door adjustment

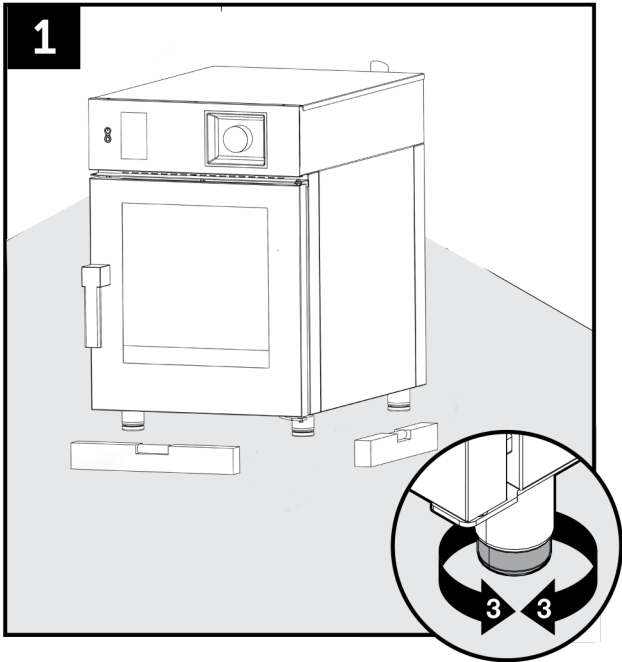

Move the Combination Oven into final position. Level front to back and side to side by turning lower legs for proper operation.

Door Adjustment

Once the oven has been correctly positioned in its designated place for installation, check the oven compartment door closing and seal of the gaskets.

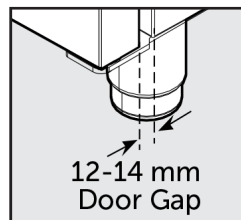

The door hinges must be adjusted to assure maximum seal of the oven door during its operation. See dimensions on door gap.

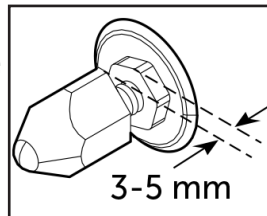

The door's catch can be adjusted in depth to eliminate any steam leaks during cooking.

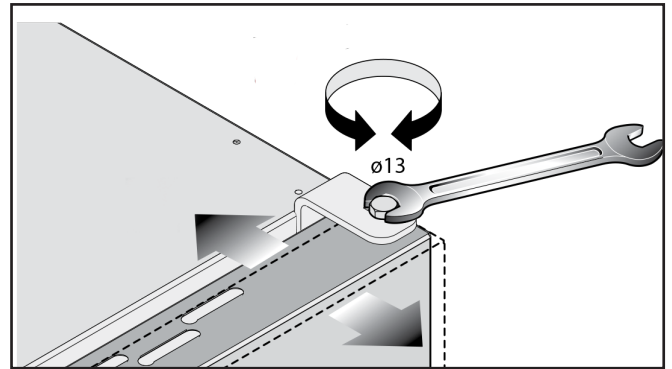

To adjust the door seal, loosen the hinge bolts and move the door to desired position. Once adjusted, tighten the hinge bolts again. See dimensions on door gap.

NOTE: Both the upper and lower hinges should be adjusted

To adjust pressure applied by the door on the gasket, open the oven door and locate the catch pin. Using a 1/2" wrench, loosen the nut on the back of the pin. Turn the pin clockwise to increase the pressure or turn the pin counterclockwise to decrease the pressure. Retighten the nut.

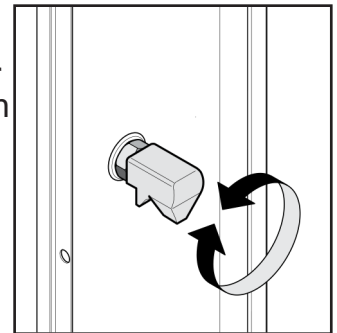

Installation, Use & Maintenance

Installation-Electrical connection

Check to make sure the electrical rating on the rating plate (located on the behind of the Combination Oven) matches the supplied electrical connection.

The oven must be properly grounded and have the electrical power lines installed in accordance to all applicable codes, regulations, and laws.

A dedicated main disconnect switch and a separate fuse or breaker for each oven should be installed.

The customer connection terminals are located behind the left side panel.

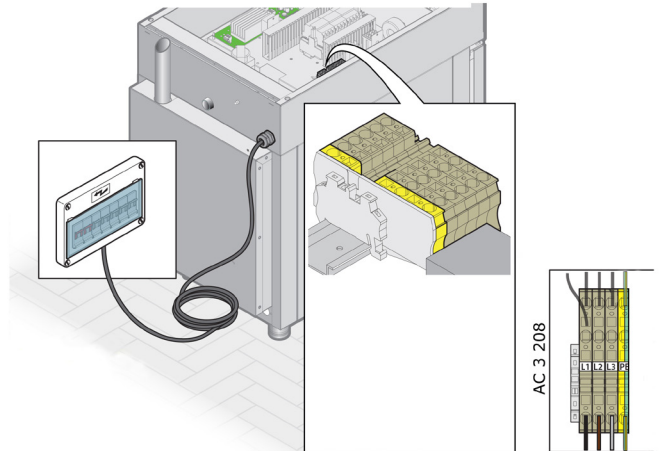

Electrical options

	Volts	Phase	Cycle/Hz	kW	Amps	Wires
6 pans	208V	1	50/60Hz	5.7	28	3xAWG12
	208V	3	50/60Hz	5.7	17	4xAWG12

	Volts	Phase	Cycle/Hz	kW	Amps	Wires
10 pans	208V	3	50/60Hz	11,4	33	4xAWG12

Installation, Use & Maintenance

Installation-Water connection

The Combination Oven requires 3/4" GHT (Garden Hose Thread) cold water connection. It is for treated water that feeds the spritzer, water that feeds the hand shower, drain quench, and cleaning system.

- If the water supply meets the minimum water quality requirements, then a single water supply configuration may be used. If a single water connection is used, a water distributor or tee should be sized appropriately to handle both water connections.
- The minimum water temperature for the correct functioning of the oven is 43° F. The maximum water temperature for the correct functioning of the oven is 75° F.
- Dynamic Pressure = minimum of 35 PSI. Should the incoming water pressure be lower than the minimum value, install a pump or adjust the pressure regulator upstream of the oven to achieve the required minimum pressure.
- Static Pressure = maximum 87 PSI. Should the incoming water pressure be higher than maximum value, install a pressure reducer upstream of the oven.
- Install the water supply lines before positioning the Combination Oven.
- Water supply lines should be located so that the oven can be easily moved for servicing.
- Check that the check valve of the solenoid valve is clean.
- Backflow Prevention — The equipment must be installed with adequate back-flow protection to comply with applicable federal, state, and local codes.

Before connecting, let sufficient amount of water flow to clean the pipes from any residues.

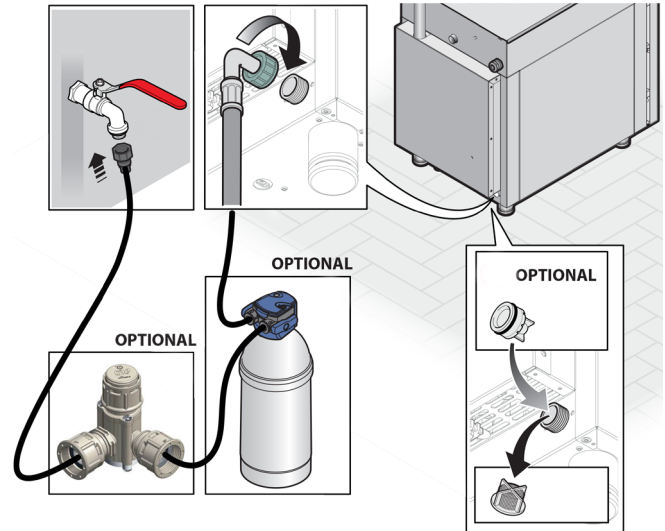

Connect the cold water supply lines to Combination Oven water connection outlets. Make sure there is a shut off between the lines and the oven, placed in an area where it can be seen and reached in case of emergency.

Installation-Drain connection

The Combination Oven is supplied with a 40 mm (1.5") drain pipe out the back of the unit. The drain line is to be installed in compliance with the Basic Plumbing Code of the Building Officials and Code Administrators International, Inc. (BOCA) and the Food Service Sanitation Manual of the Food and Drug Administration (FDA) and any other applicable national, state, or local codes and regulations.

Do Not install the Combination Oven directly over a drain. Steam rising up out of the drain will adversely affect operation, impede cooling air circulation, and damage electrical and electronic components.

NOTICE

Improper installation of drain outlet line voids the Combination Oven warranty.

The following requirements are critical to the safety of personnel and equipment and must be adhered to under any circumstances.

- The drain for the Combination Oven should be made of stainless steel or an equivalent temperature-resistant material (minimum 175° F).
- **Do Not** connect drains from any other equipment to the drain line of the Combination Oven.
- **Do Not** connect the drain outlet extension line directly into a floor drain or a sewer line.
- The drain line must be free air vented, have gravity flow from the oven, and terminate outside the perimeter of the oven. **Note:** Free air venting requires minimum 1" clearance between the end of the drain line and the top of the floor drain.

- The drain line must have gravity flow from the Combination Oven drain outlet to floor drain.
- **Do Not** install a trap in the drain line.

The total length of pipe and number of bend fittings required to reach the open drain determines the pipe size used to extend the drain line to an open drain.

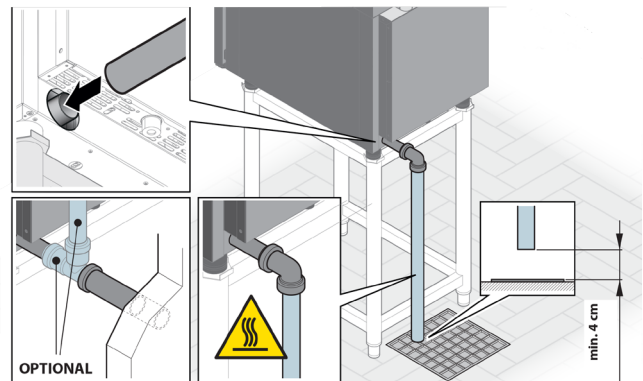

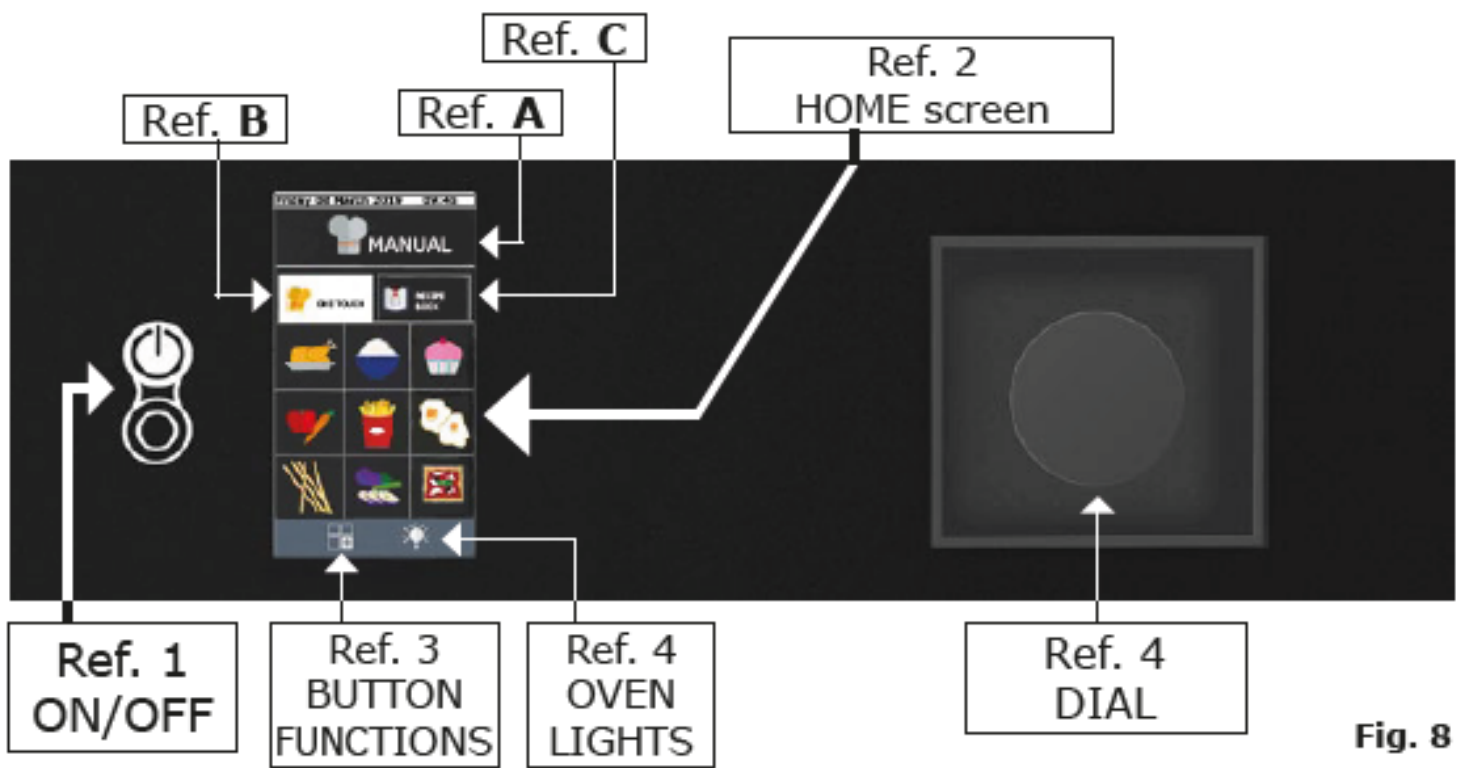

Fig. 8

Installation, Use & Maintenance

Cooking

Pictograms key

Start screen

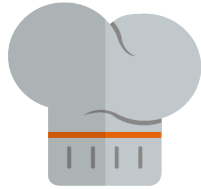

MANUAL



ONE TOUCH



RECIPE BOOK

 Pasta and rice	 Meat	 Fish
 Poultry	 Bread	 Vegetables
 Desserts	 Extra	 Multitimer



FUNCTIONS



CHAMBER
LIGHTS

Installation, Use & Maintenance

Manual cooking screen



Cooking mode: convection



Cooking mode: mixed



Cooking mode: steamed

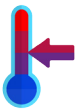

Mode: maintenance

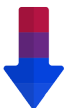

Automatic cooling.
Present only from phase 2.



Mode: smoking



Time /timer



Core probe mode



Delta-T mode



Humidity discharge
valve: closed



Humidity discharge
valve: open



Relative humidity percentage



Unlock key: allows a program to
be changed



Indicator of program changed by
the user, or new program



During cooking, it allows the
program SET to be checked



Manual humidifier key



Programmed start key



Home key: brings one
back to the start screen



Mode cooking: steam standard



Mode cooking: intensive
steam

Home screen

Switch on the oven by pressing the "ON/OFF" key (Ref.1 Fig.1), the home screen will appear on the display "Home" (Ref.2 Fig.1)

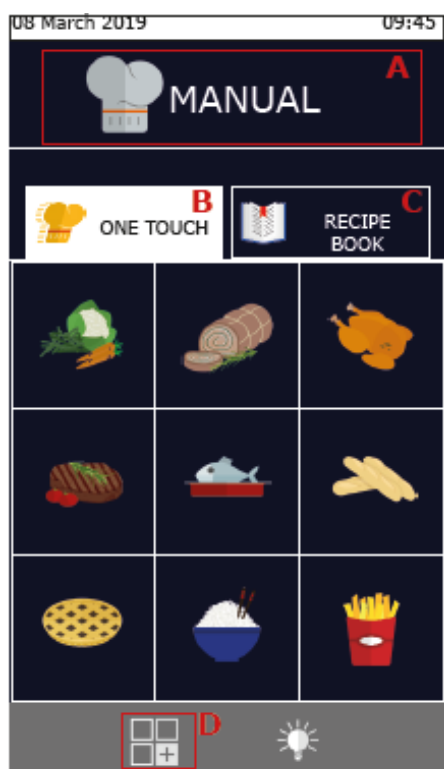

It is possible to choose between "Manual" cooking (ref.A), or using the favourite programs set by the user in the "recipe book". (ref.B)

By pressing button C, access is given to the "Functions" menu where it is possible to set washing, import and export the cooking programs and change the oven system settings. (some of these functions are password-protected and reserved exclusively for specialized technicians.

Instead the "Recipe book" (ref.B) groups cooking programs, divided by product type, as for example: meat, vegetables, desserts, etc.

How to interact with the touch-screen

All of the operations can be selected by clicking on the desired item or pictograms.

To modify a cooking parameter, e.g the temperature, click on the relative field and turn the knob.

To confirm the modification, click on the parameter again or press the knob.

Manual cooking mode

From the "Home" page, by pressing on "Manual" access is given to the cooking parameters setting screen.

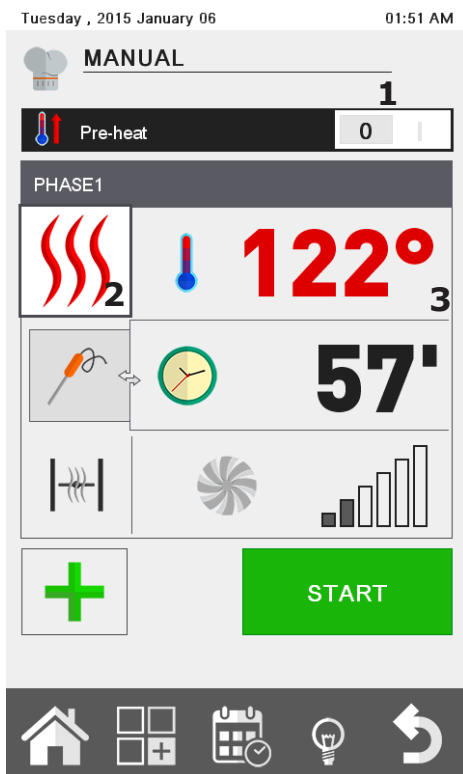

In "Manual" mode, the oven can be set for individual cooking with one or more phases and/or a cooking program can be set and saved in the recipe books.

Setting automatic pre-heating

The "preheating" function heats the oven to the desired temperature before the dishes to be cooked are introduced.

If the oven temperature is higher than the one indicated for pre-heating the oven, the oven will auto-matically cool down to the correct temperature.

"Pre-heating" is set automatically, but this function can be modified after the "start" button has been pressed, by clicking on the temperature displayed.

By pressing button **1** on the left or right, this function can be enabled or disabled.

Preheating with oven empty.

Setting the cooking mode

Button **2** is set as default in the convection cooking mode (hot air). By pressing this button, the cooking mode can be changed to mixed or steam. Alternatively, set a maintenance cycle (HOLD) or set a message cycle. Furthermore, the oven can be set in smoke mode.

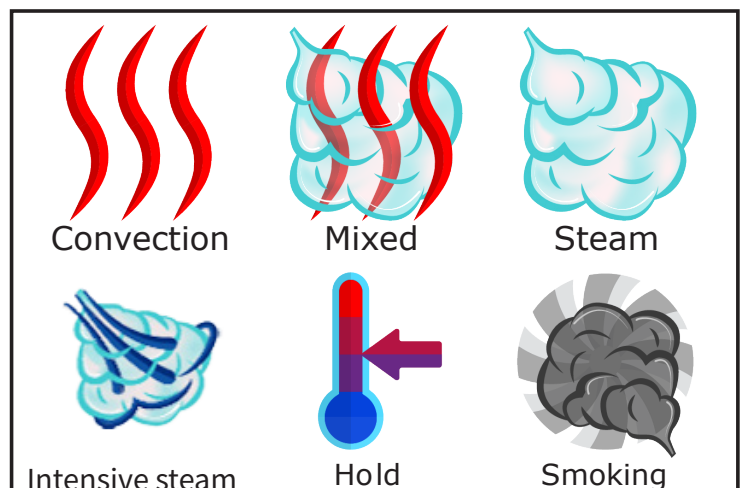

Cooking modes: convection, mixed and steam

Setting the cooking temperature

By pressing the button **3**, you can set the cooking chamber temperature. The temperature that can be set varies depending on the selected cooking method.

Setting the timer / probe / Delta-T

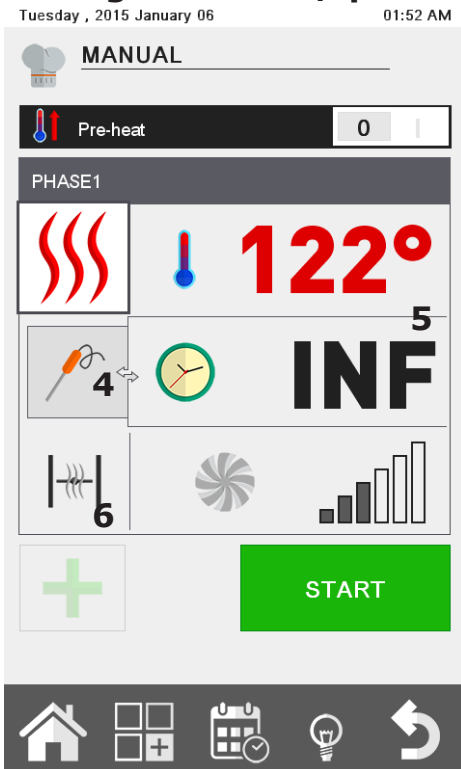

Having selected the "Cooking Mode", you can cook in "timed" mode or using the "core probe".

By pressing button **5**, you can set the timer (count-down).

The time is indicated in the minutes format (1h30' = 90 minutes).





On expiry of the time, the oven emits a sound and cooking stops.

If the time is not set, cooking will take place in "infinity" mode (**INF**), the oven will continue to cook until the operator intervenes manually to stop cooking.

When cooking with the "core probe" it is possible to choose between pin (**4a**) or **ΔT** (**4b**).

This mode allows the product to be cooked more accurately.

Further information regarding **ΔT** cooking is described in chapter 2.16.

	4a Cooking mode with core probe
	4b Cooking mode in ΔT
	6a Valve closed
	6b Valve open

Setting the humidity vent valve

Only in convection mode is it possible to manually set the opening or closing of the humidity discharge valve. When it is open, the humidity present in the cooking chamber is evacuated, thus allowing the cooking chamber, and therefore the product, to dry. Press button **6** to maneuver the valve

Setting the relative vapor percentage

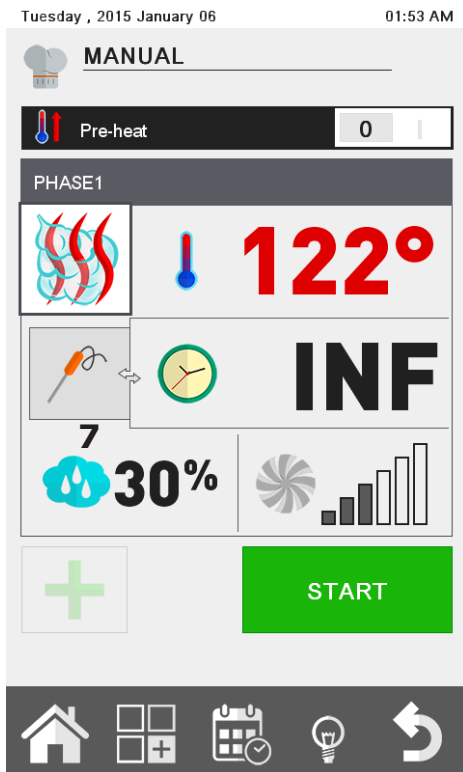

Only in "Mixed" mode is it possible to set the percentage of humidity that the oven will maintain during cooking.

To set the desired level of humidity, press button **7** and set the valve.

Setting fan rotation speed

The fan rotation speed parameter can be modified in the "Convention" and "Mixed" modes.

Instead, in the "Steam" mode, this setting is automatic.

Fan operation, in relation to the temperature set, is mainly is that of evenly distributing the heat inside the oven chamber for uniform cooking and browning of the products on the various trays.

To set the rotation speed, press button **8** and select the desired level.

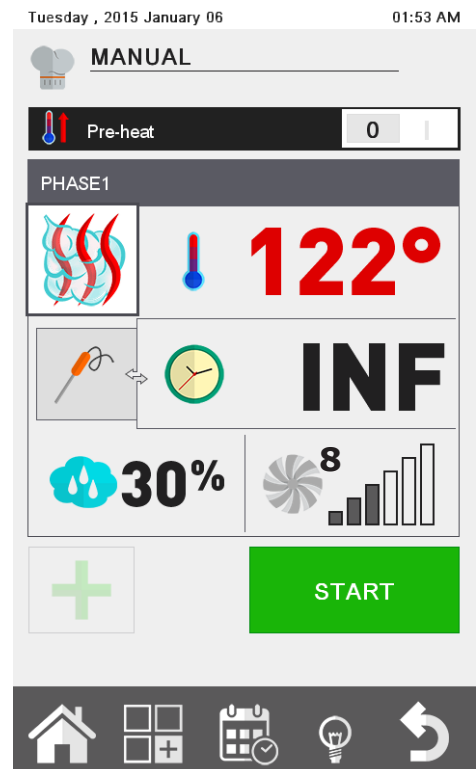

Hold Mode

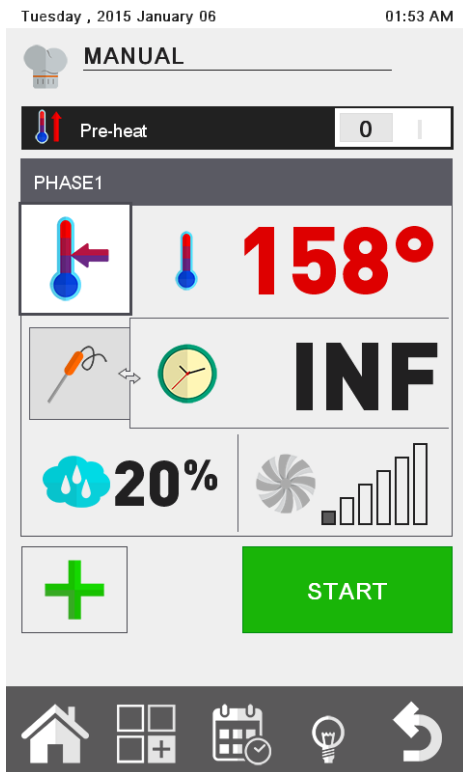

The hold mode has the purpose of maintaining the products at a hygienically safe temperature (> 149°F) without product core cooking undergoing changes. It is used at the end of night time cooking to maintain the products cooked until the operator returns.

The HOLD mode by default has humidity set at 20% and the fan at speed 1. For effective maintenance, it is recommended not to modify fan speed. In the case of roasted products, the hold humidity setting is recommended between 20% and 35%, in the case of brazing or stewing, humidity is recommended between 90% and 100%.

To modify the hold phase, click on the cooking mode button (2) and select HOLD.

Smoking mode

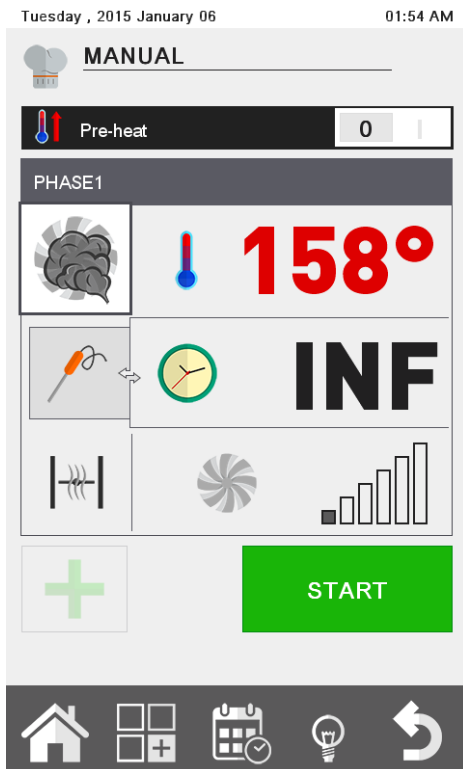

The "Smoker" accessory is required to perform smoking in the oven. This must be inserted into the oven on one of the trays before the smoking phase begins.

If the cooking program envisions a cooking phase successive to the smoking phase, the "Smoker" accessory must be removed from the oven. Refer to the accessory manual for further information regarding the connection and use of the smoker.

Once cooking has been started by pressing the Start button, the oven will ask for the smoker to be introduced before the smoking phase begins. At the end of the smoking phases, the oven will request the removal of the smoker.

Both these passages must be confirmed by the operator. Only after confirmation will the oven pass to the next phase.

The temperature, time, ventilation and humidity discharge valve can be adjusted during smoking. It is recommended to keep the latter closed so that smoke does not escape from the chamber. Smoking can be performed both hot and cold, depending on the type of product and the desired result.

In the first case, set a temperature between 50°F and 86°F. The minimum temperature in the oven chamber will be similar to room temperature. The chamber can be cooled further by inserting ice.

The maximum temperature that can be set in this mode is 392°F.

Starting and stopping cooking

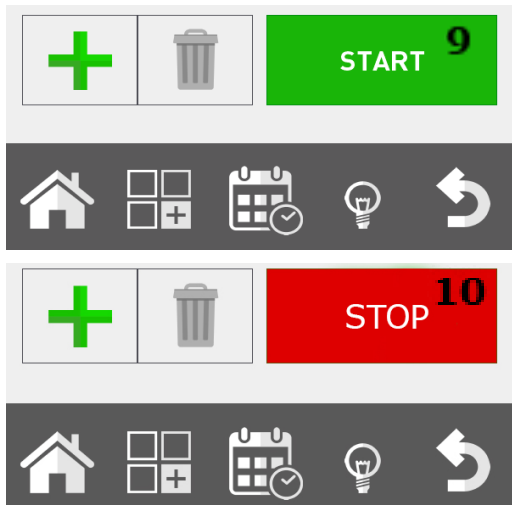

After setting the cooking parameters as desired, press the START button, button 9, to start cooking. The oven will start in pre-heat mode if this has been previously selected, or otherwise directly in cooking mode. By pressing “Advanced Customization”, you can manually select the specific starting phase for cooking or move from one phase to another of the cycle by selecting the desired phase and pressing the GO button which is displayed next to the phase number. Cooking will last until the expiry of the time set or on reaching the core temperature in the core probe cooking mode. If the time is set on infinity, cooking must be stopped manually. To stop cooking, press STOP, button 10.

Customized cooking programs

It is possible and easy to create customized cooking programs that can have up to 9 different phases plus pre-heating.

Every cooking phase is represented by a cooking mode (convection, mixed, steam, etc.) With specific time, humidity, ventilation parameters, etc.

For example: for a roast dish, a program can be created that contains a browning phase, a cooking phase and a hold phase.

The essential condition for creating a successive phase is that the previous phase has a defined time: example, if phase 1 has the time set on infinity, it will not be possible to create phase 2 because the first phase has no end. The hold phase is an exception, which can be set on “INFINITY” and then have one or more successive phases, which must however be started manually. E.g. in the night time cooking of roast dishes, you may prefer to brown the dish when the operator returns to the kitchen, therefore after the hold phase. To pass from one cooking phase to another, hold the number of the phase to which you want to pass down, or use the arrows to select the desired phase number and press the “GO” button at the side of the phase number.

The program of a specific phase can be started (different from the first set): after having selected the program, press the “Advanced Customization” key and use the arrow to go to the desired phase. On pressing Start, the program will start from this phase. If pre-heating was envisioned in this program, it will not be performed. The program can be modified using the Recipe Tuner interface before pressing the “Advanced Customization” button.

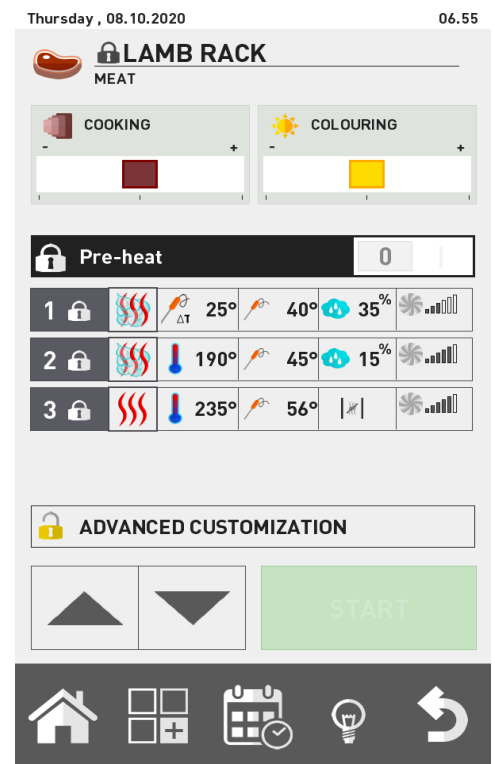

Creating a cooking programs

A cooking program is made up from several phases, which the oven performs in increasing order (phase 1, phase 2, phase 3...) passing from one to another automatically.

After setting the parameters for the initial phase (phase 1), press the new phase (button 11) to create the next phase.

Therefore, set the parameters of phase 2.

Continue with steps 1 and 2 to create additional phases. You can also create and enter new phases between previously created phases. The new phase will be placed under the one selected when you press the "new phase" button.

At the end of programming, press START to start cooking. To delete a phase, select it and press the button "Eliminate Phase" (button 12).

Setting a cooling phase between two phases

The temperature inside the oven chamber may have to be cooled between one phase and another.

For example, when roasting the chamber needs to be cooled between the browning phase (at high temperature) and the cooking phase (at low temperature).

This operation can be performed automatically by the oven by setting an automatic cooling phase.

The automatic cooling phase can only be set from phase 2 onwards.

After having set a high temperature phase, create a new phase and select automatic cooling from the cooking modes range (ref. 2).

Once this mode has been selected, the oven will propose its default temperature, ventilation and humidity discharge valve values. Set the desired cooling temperature (min. 212°C).

In order to make cooling as fast as possible, do not modify the ventilation and humidity discharge valve values unless indispensable.

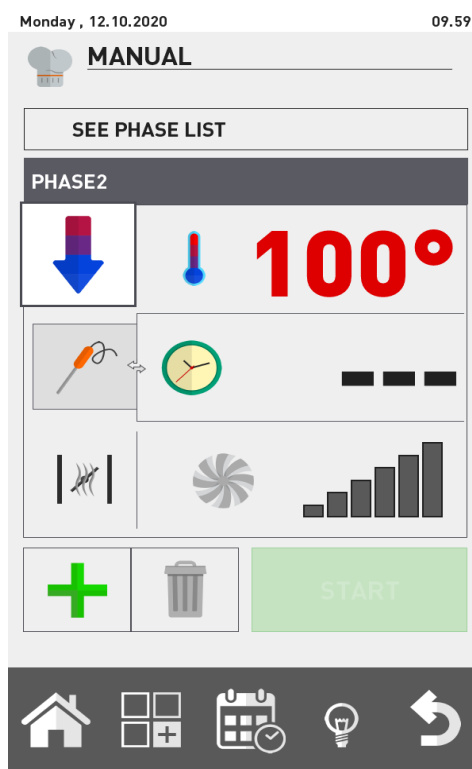
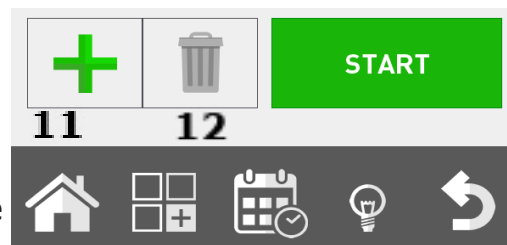

Installation, Use & Maintenance

Saving a cooking program

A cooking program created can be saved, for use at a later date, in a 'product type' group in the classic recipe book (meat, fish, chicken, etc.).

After having created a cooking program, press the functions key to access the programs function screen.

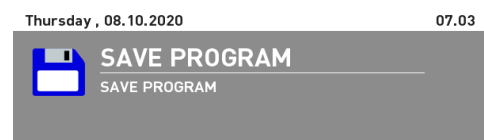
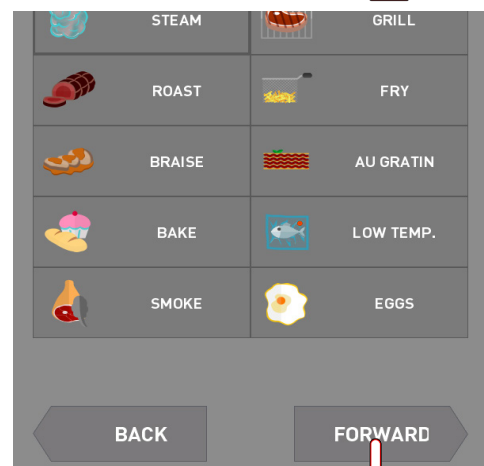
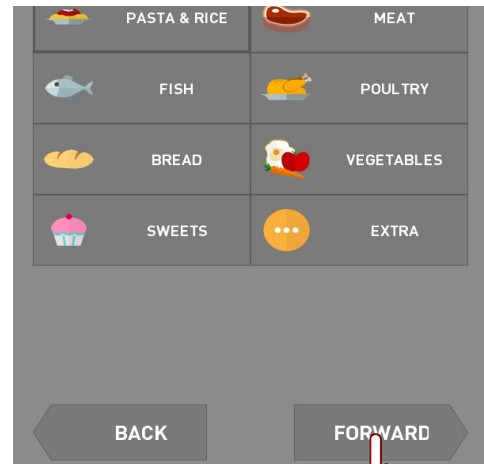
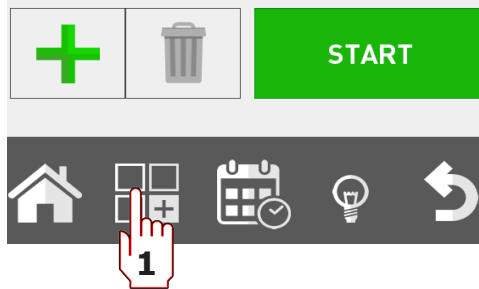

Roast



Modifying a cooking program

On delivery, the oven will already contain cooking programs. Both the pre-loaded cooking programs and the new ones created can be customized.

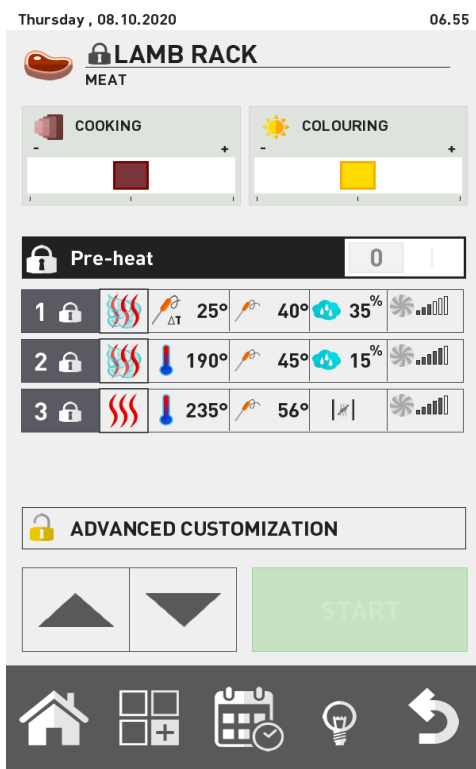

On delivery, the oven will already contain cooking programs. Both the pre-loaded cooking programs and the new ones created can be customized.

To modify a program, first select the desired program from one of the recipe books. Once open, a summary of the phases set can be seen. In this 'reading' mode it is not possible to modify the cooking parameters. If one or more cooking parameters are to be changed or automatic pre-heating is to be activated/deactivated, click on the "Advanced customization" (button 18) to release the program and make the desired modifications. Select the phase you want to modify by turning the encoder (button 19) and change it as required. After making the change, you can start cooking directly (in this case, the changes will only apply to this cooking cycle and will not be saved) and/or create a copy of the program with a different name which includes the changes made.

You cannot save modifications to pre-loaded programs.

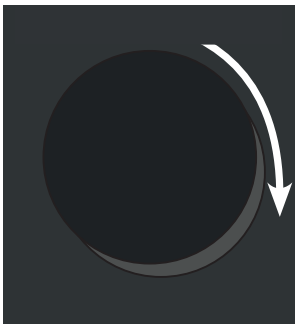

Copy, move, rename, and delete

Every program present can be copied, moved, renamed or deleted totally or partly.

Copy a program

If a new program is to be created by starting from a program already present (because the old and new program share cooking aspects, it can be copied. Select the base program, open it and modify it clicking on Advanced Customization. Make the desired modifications and using the functions menu (button 15) select save and then, copy.

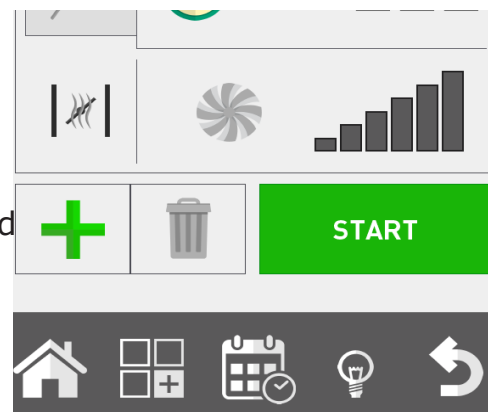

15

Shift a program

If you want to move a program from one group to another, open the program and click on the functions key (button **15**). Select Save then Move. Select the new group or new groups in which to move it and confirm with the next key.

Rename a program

After opening the program, click on the Functions key (button **15**) and select rename. Type in the new name press enter.

Delete a program

After opening the program, press the functions key (button **15**) and click on Save, then delete. Confirm the choice by clicking on YES in the pop-up that is shown.

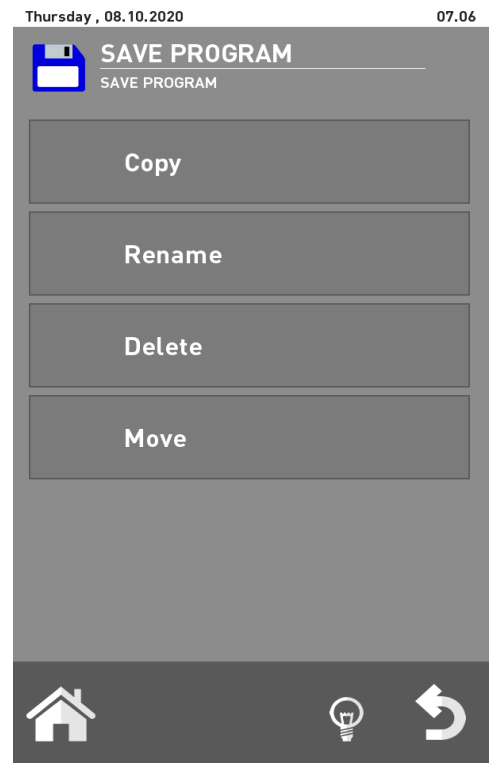

Selecting a program from the menu

The oven is supplied with a series of cooking programs pre-loaded in the memory. These are divided by product type (meat, fish, vegetables, etc..) You can view them from the main menu under "recipe book".

The product recipe book.

By clicking on the recipe button, the cooking modes will be displayed divided by product category, e.g. meat, fish, vegetables. By selecting the desired product category, the list of all cooking programs will open relative to that category. Select the desired program from the list.

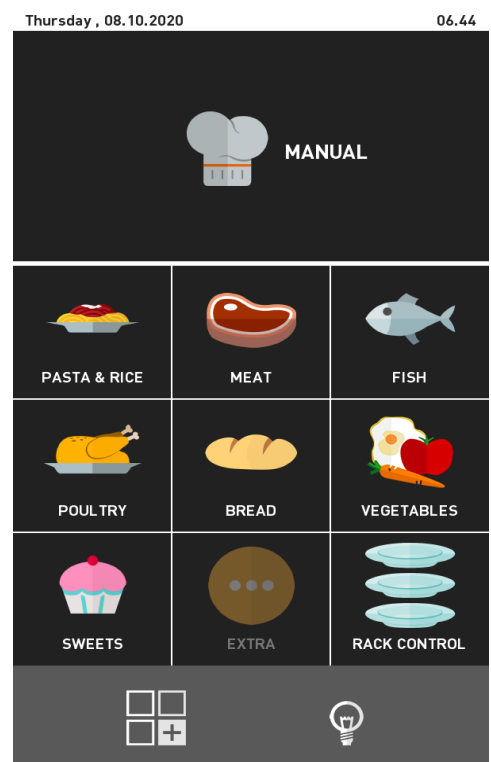

The RecipeTuner interfaces

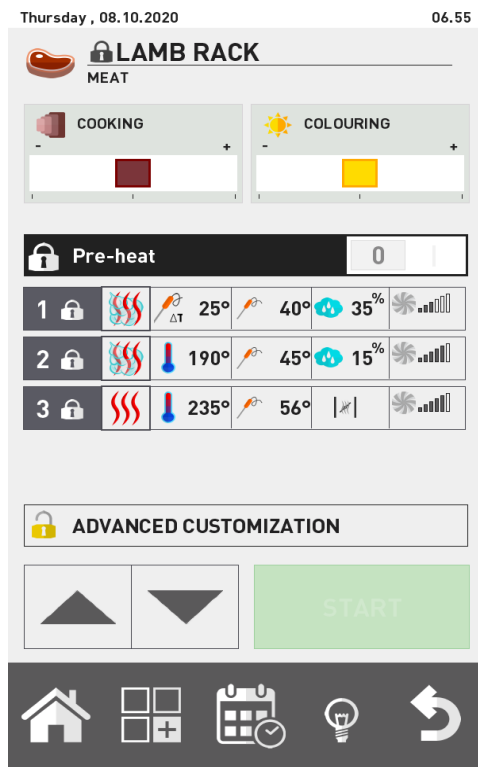

Once a cooking program has been opened, it can be modified simply by using the RecipeTuner interfaces. Depending on the type of cooking selected, the cooking, browning, degree of rising, etc. of a product can be easily modified.

The **RecipeTuner** function is present for the pre-set programs and the new ones created. The **RecipeTuner** system recognizes the phase to be modified in order to meet cooking requirements.

Function of the interfaces

Cooking: allows modification of the cooking of a product. Starting from average cooking at 140°F starting from the left the following types of cooking will be obtained: "rare", "medium-rare", "medium", "medium-well done" and "well done".

Browning: product browning can be modified on 5 different levels from the lightest (on the left), to the most intense (on the right).

Humidity: when braising, it refers to the residual humidity on the product at the end of cooking.

Rising: it is possible to add the degree of rising (20-minute steps) to then perform an automatic rising and cooking program.

Cooking method	Interfaces	
Steamed	Cooking	
Grilling	Cooking	Browning
Roasted	Cooking	Browning
Frying	Cooking	Browning
Braising	Moisture	
Au gratin	Browning	
Bakery products	Leavening	Browning
Low temperature	Cooking	
Smoked		
Eggs	Cooking	

The product recipe book.

The **Multitimer** function is the function that allows separate control of up to 10 different levels during cooking.

This function manages a unique "Cooking Mode" setting, temperature, humidity, etc. However, each level may have a core cooking time or temperature independent from the others.

Once the **Multitimer** icon (button **16**) has been clicked, you access the list of pre-set programs, such as: Breakfast, Lunch, Multibaker, Mixed steam. Each of these programs will contain a series of dishes regarding the program.

Example: the Lunch program will contain the dishes regarding the lunch service such as the grilled steak, Milan style meat, stir-fried vegetables and lasagna.

It is possible to create and add other programs and sub-programs (dishes).

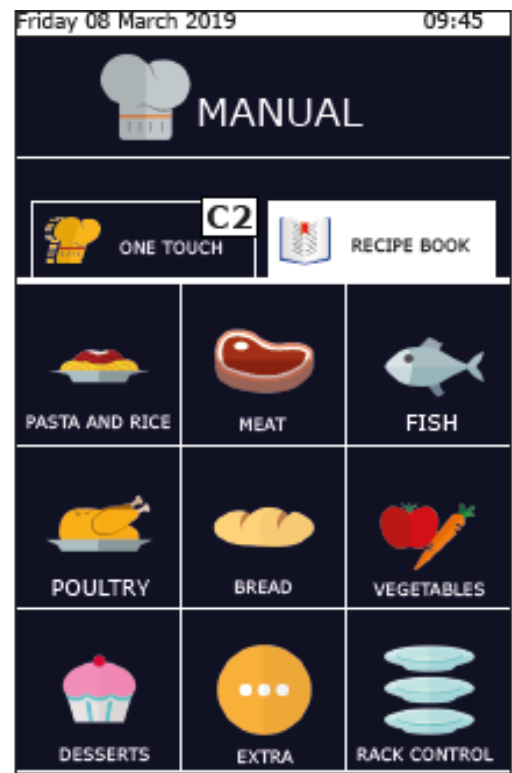

Using the Multitimer function

Selecting a Multitimer program

By selecting one of the programs from the list, for example: "Lunch", will open a screen with the general program settings on the left: Pre-heat, Cooking Mode, Temperature, Fan, Butterfly valve (or humidity or SteamTuner if the Mixed or Steam) cooking mode is set. The 5 empty levels will be seen in the right part.

Starting a Multitimer Program

All Multitimer programs function basically with infinite time. Therefore, regardless of whether the program includes pre-heating or not, the first thing to do is start the program by pressing START (button **17**)

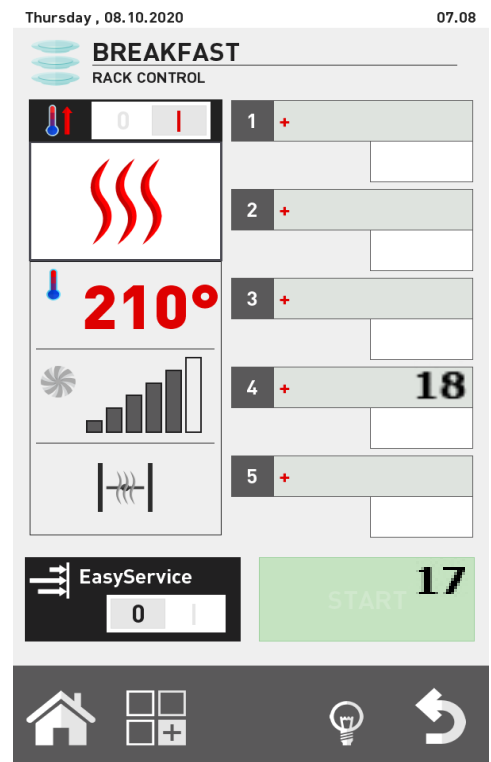

Add the dishes to the program levels

After starting the program and at the end of pre-heating (if present), click on + (button 18) of any one of the right-hand boxes to add the name of the dish to enter in the level selected.

The list of sub-programs already set will then open (dishes). Select one by clicking in it and this will automatically be added to the previously selected box. Before selecting a dish, it must be placed inside the oven for cooking. Continue by adding the rest of the servings that are to be cooked. It is possible to add and manage up to a maximum 5 levels per time.

The time remaining until the end of cooking will be seen at the side of the level name or, if probe pin cooking has been selected, the real core temperature.

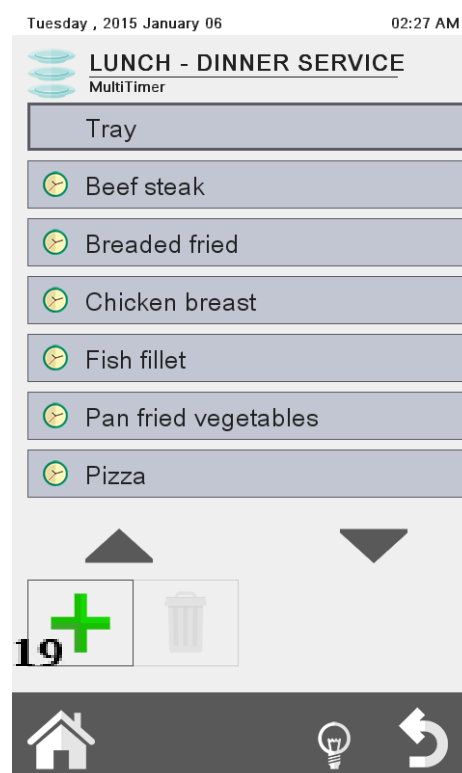

Create new names for dishes for the levels

New dish names can be added both to the programs created by the user and to those pre-set. Enter the list of dishes and click on an empty box, press "New" (button 19).

Enter the name of the serving into the screen along with the cooking time and the core temperature. Finally press the "Save" icon (button 20). Continue by pressing "New" to add others.

Delete a dish from the list

A serving is deleted from the list by simply pressing the name to be eliminated. this operation is only possible if the cooking of this dish is NOT active.

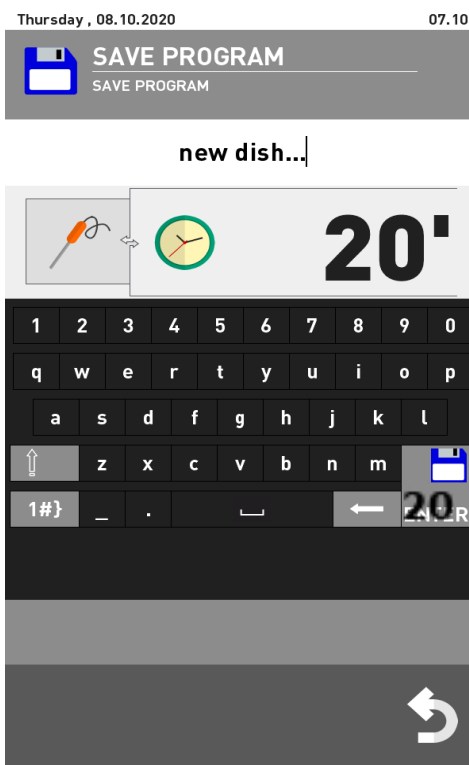

Direct or scheduled use

Multitimer can be used in direct mode and in scheduled mode.

The first mode is that described in the previous chapter (Add the plates to the program) in which the dishes are added after having pressed the START button (and at the end of pre-heating, if present).

In the programmed mode, instead, the servings are added when the oven is in STOP mode, i.e. when it is not cooking. In this, the levels selected will not activate. Only after having pressed START (and having waited until the end of pre-heating if present), can they be activated one by one, by clicking on the time box on the right.

Modifying the time or the temperature of the dish probe

The cooking time or the core probe set of a dish can be modified by prolonged pressing of the same.

To modify definitively, enter the list of dishes, select the name of the dish to be modified by prolonged pressing. Enter the new time (or probe temperature). The name of the serving can also be modified in this way. If, instead, the time of a serving is to be changed during cooking, click on the remaining time box and enter the new time or temperature probe.

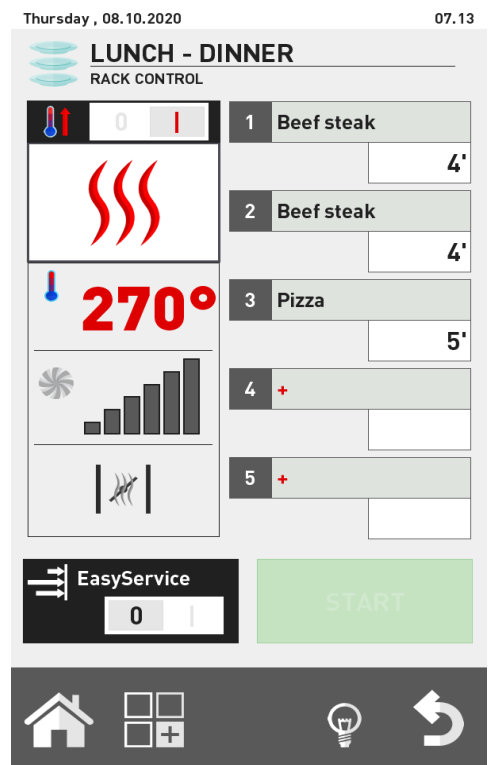
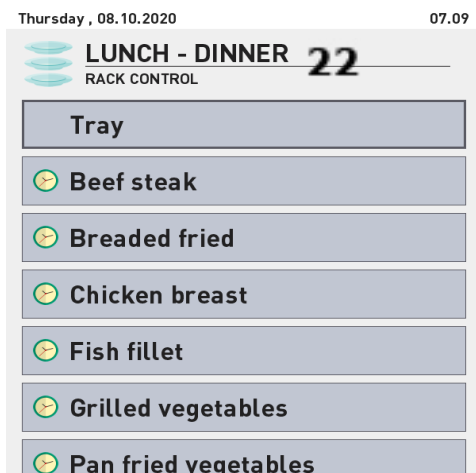

The end of cooking a dish

When the pre-set cooking time of a dish has finished (or when the core temperature set has been reached), the oven will emit an audible signal and the message "END" (22) will appear in the time box. Just open the oven door and remove the product that is ready. Opening and closing the door will automatically reset the level.

Quick entry of a dish

During the cooking and service phase, you may need to cook a product that is not on the list. It is possible to quickly insert a dish in the RackControl without having to record it with a specific name. The generic name of "Tray" will appear. To do this, click on an empty level and select the sub-program named "Tray" (22).

This represents a spare sub-program to which a different time can be set every time.

Several "Tray" servings can be introduced into the RackControl simultaneously.

Modifying a Multitimer program

If a Multitimer program is to be modified, once open, modify the sets shown in the left-hand column (23). The cooking mode, temperature, fan (excluding steam mode) and butterfly valve can be modified at any time.

It is also possible to save the modification made or copy, rename and delete the program. In this case, press the functions key (24) and proceed as explained in chapter of this instruction manual.

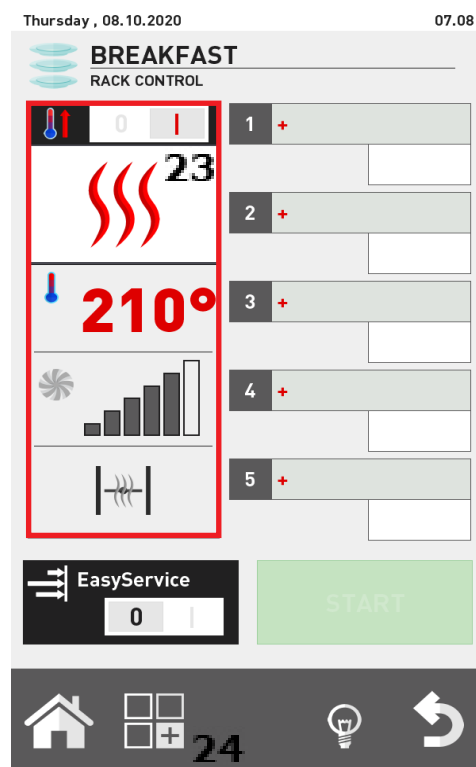

Creating a new Multitimer program

In addition to the Multitimer programs already present, customized programs can be created. Enter the list of Multitimer programs (from the Home screen, click on the Multitimer icon). The first program shown at the top is:

"Manual" (25). The "Manual" program allows the creation of a new program and also to work in RackControl mode without memorizing the program. In the second case, on exiting the program, the cooking sets set will be lost.

To create a new program, enter the "Multitimer Manual" section and enter the desired cooking sets into the left-hand column.

Only after the program has been memorized is it possible to enter the list of dishes.



Using the Multitimer in "Manual mode"

If the program set is to be saved, Multitimer can be used in manual mode. However, in this mode, specific dishes cannot be saved. The generic name "Tray" will be displayed for all levels instead.

Using the EasyService Function in Multitimer

Multitimer is designed to cook the dishes separately on distinct levels. The servings can be introduced at the same time or different times as the times expire, the oven informs which level it has reached at the end of cooking.

By activating the EasyService function, it is possible to have all of the dishes ready at the same time. In this way, the oven informs when it is necessary to insert the servings at the various levels in a way that they are ready at the same time. In this way only levels with the time parameter setting can be selected (not with the core probe parameter).

Activate EasyService

The EasyService function must be activated before pressing the START button; in fact, it is only available when the oven is in STOP mode.

To activate EasyService, slide the switch of the EasyService (button **26**) to position I.

This action allows access to the list of dishes of the relative RackControl program. Select the dishes to be served at the same time (maximum 10) and press the START button.

Once pre-heating (if present) has ended, the oven signals to put the dishes with the longer cooking time in the oven. An acoustic signal is given and the word "IN" is displayed in the right-hand box. With the opening and closing of the door, the acoustic signal is reset and the countdown begins.

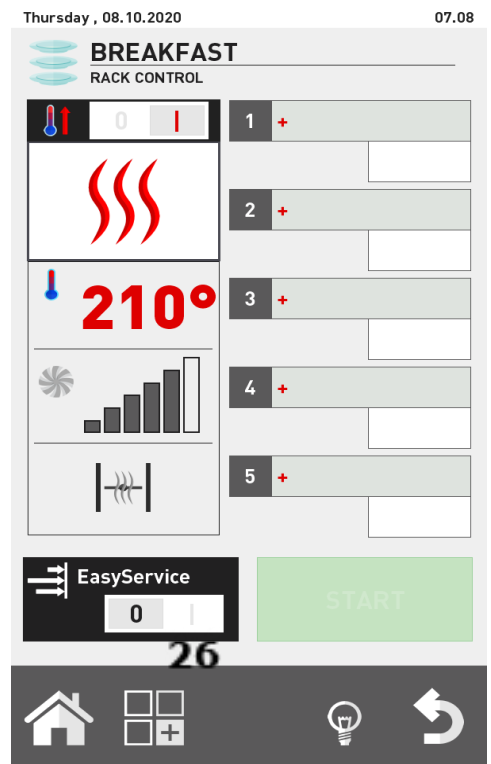
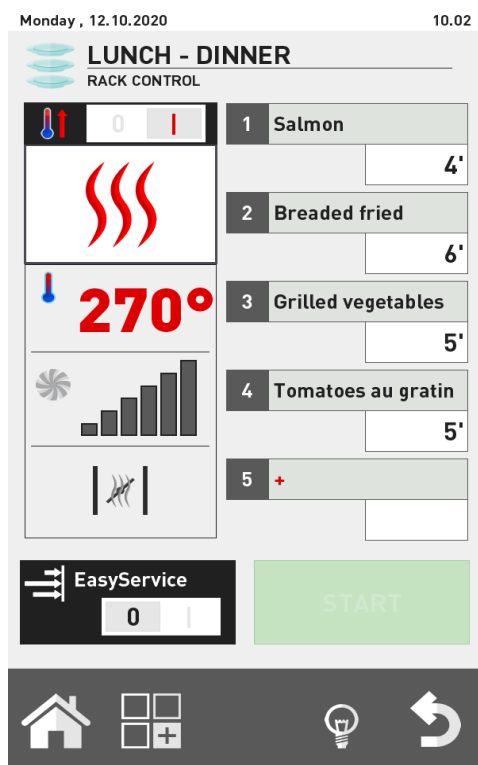

In the other levels, the residual time to placing in the oven is highlighted in green. The oven warns when the other servings must be placed in the oven in the same way. The acoustic warning starts in an intermittent manner starting from -15 seconds. It is recommended to wait until the timer reaches 0 and the wording "IN" is displayed before placing in the oven. In this way, all of the dishes will be cooked exactly at the same time.

Using Multitimer with EasyService

During the use of EasyService, other plates can be added in Multitimer mode, which will be controlled independently from those selected for EasyService. Both functions can be used at the same time only by activating EasyService first and then adding other plates in Multitimer mode. EasyService cannot be activated if RackControl is already activated.

Programmed Start

A cooking cycle can be programmed to start by selecting button **27**. Select the year, month, day, hour and minutes from the screen and save the setting. Once the setting has been saved, the oven cannot be switched off and additional cooking programs cannot be started.

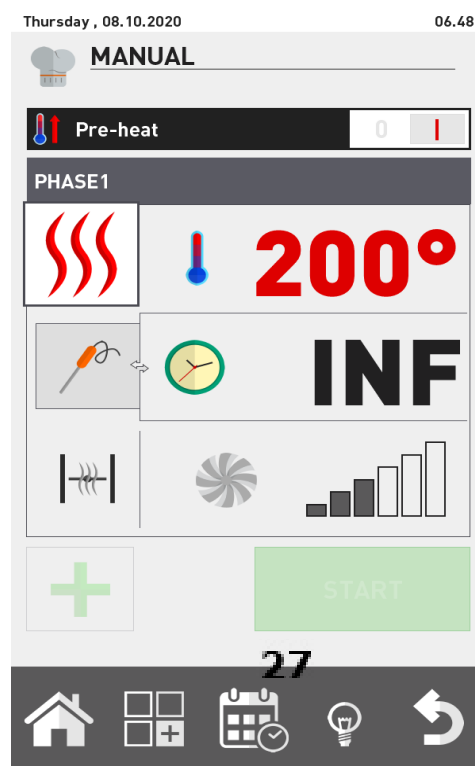

The core probe and cooking in ΔT

Positioning the probe

The probe detects the temperature via a tip positioned in proximity of the probe. This must be inserted in a way that the tip coincides with the center of the product in the largest part.

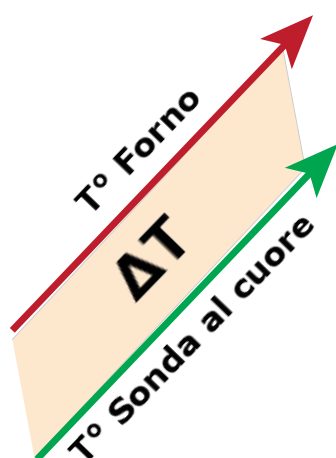
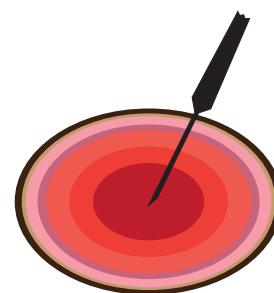

Cooking in ΔT (Delta-T)

The ΔT function is used mainly for slow, low temperature cooking.

In ΔT mode, instead of setting the temperature in the chamber, the temperature that the oven must maintain constant between the product core temperature and the chamber camera is set. As the core temperature rises, the temperature in the chamber will increase at the same time. A probe must be used for the ΔT function. It is advisable to set the ΔT between 59°F and maximum 30°C.

Cooking temperatures at the core

Food	Cooking	T° core
Red meat	Rare	122°F
	Medium	140°F
	Well done	158°F
Veal, pork and white meat general	Well done	158°F
Chicken	Well done	176-194°F
Boiled and braised meat	Well done	176-194°F
Fish	Well done	153-162°F

Recommendations for cooking: roasting, grilling and frying

Roasts

For more effective cooking, it is recommended to place the roasted foods on the steel rod grill in order to achieve more uniform cooking between the upper and lower part without having to turn the product during cooking.

If you want to collect the juices, place a tray on the lower level of the oven.

Grilling

The grill accessory must be used for grilling in the oven. The grill must be in aluminum for the best results to be obtained.

The oven is generally set in convection mode, with valve open and temperature between 446°F and 518°F according to the type of product and browning that is to be obtained and ventilation between 4 and 6.

Frying

All breaded and precooked frozen foods can be fried. In the case of breaded products, spray a thin layer of oil in a way that it is absorbed by the bread. Frozen precooked products can be fried without adding oil.

Use non-stick aluminum trays or relevant frying baskets. Set the convection oven with the valve open, at a temperature of 482°F and ventilation between 4 and 6.

Cooking advice: cooking uniformity

The uniformity of cooking could be modified according to the type of product introduced. In this case, it is recommended to try and lower the temperature and operate (increasing or decreasing) the fan rotation speed.

Using correct trays increases the general cooking uniformity of the oven. Always select the tray with the minimum depth possible for the product to be cooked.

Aluminum trays offer more uniform cooking than steel trays.

Cooking recommendations: vacuum cooking and pasteurization

Vacuum cooking

A product can be cooked directly inside a vacuum bag. This type of cooking allows particularly soft and flavored meat to be obtained and at the same time decreases the perishability of the product.

After having vacuum packed the product via the use of relevant cooking bags, set the oven with the MIXED CYCLE at 100% humidity and ventilation between 3 and 4. The cooking chamber temperature must be maximum 3°-5°C above that which the core must reach. E.g. for an average fillet (140°F at the core), set the oven temperature at 145°F.

Pasteurization in jar

In the pasteurizing processes, the product is considered pasteurized when the core temperature reaches a value between 181°F and 185°C.

On the basis of the type of product, dimension of the jar and amount of product it contains, the time of reaching the core temperature may vary. It is therefore recommended to use the core probe on a sample jar (perforating the lid to allow the probe to enter) in order to detect the temperature of the entire production batch. At the end of cooking the product must be blast frozen quickly to +37°C to end the pasteurization cycle.

FUNCTIONS Menu

The FUNCTIONS menu, accessible from the "HOME" screen allows access to the main routine maintenance functions and oven use settings.

Washing (if envisaged)

In the FUNCTIONS menu, the first item is "WASHING".

There are 3 types of washing that can be selected: HARD, NORMAL and SOFT, or the RINSE ONLY mode.

The selection of one of these types of washing depends on the amount of food residues and deposits of fat in the oven cooking chamber; HARD is used for in depth washing for very resistant dirt, SOFT for a light wash.

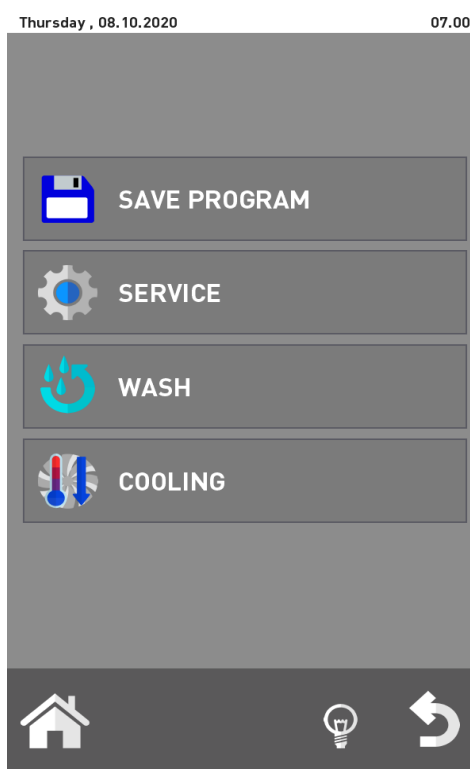

Washing duration varies on the basis of the type:

Washing type	Washing duration	Detergent consumption
SOFT	48 min.	11 ounces
STANDARD	53 min.	13 ounces
HARD	58 min.	16 ounces
RINSE	4 min.	//

Installation, Use & Maintenance

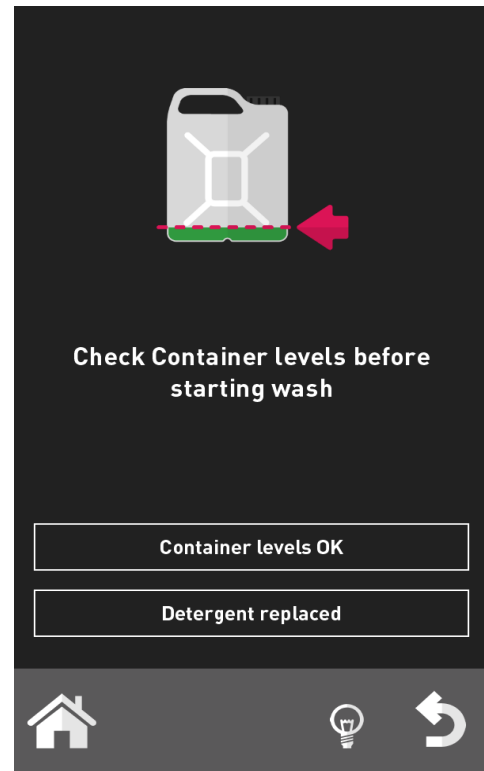
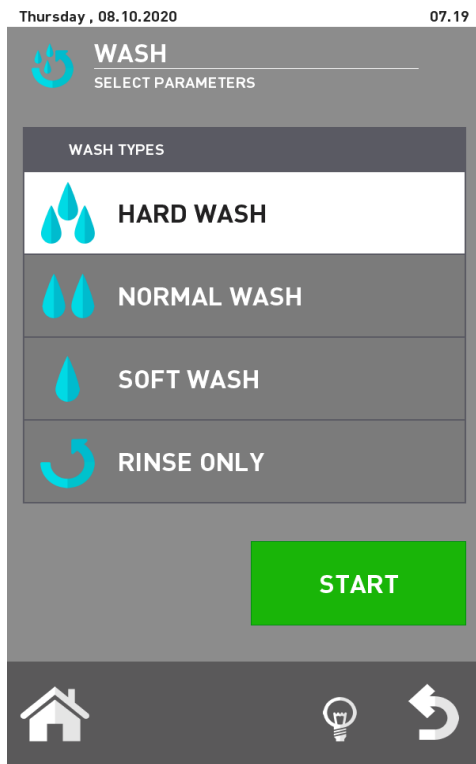

The “**Rinse only**” mode lasts **approximately 8 minutes**. After these selections and after pressing the “OK” button, you will be asked to check the product levels in the tank.

IMPORTANT

For correct maintenance and quality maintenance of the oven chamber, it is mandatory to use the detergent recommended by the manufacturer.

THE USE OF A DIFFERENT DETERGENT CAN INVALIDATE THE WARRANTY!

Cooling

This function allows to quickly reduce the temperature inside the oven chamber, to pass from a high temperature type of cooking, to more delicate cooking, which requires lower temperatures (e.g. to pass from roasting to steaming vegetables).

To start this function, press the START key and the fan will begin working. Open the oven door to promote the exit of hot air and the entry of cooler air. This allows the desired temperature to be reached in a short time and to proceed with more delicate cooking.

For safety reasons, the cooling function can be enabled only with the door closed.

The door can be opened only after this program has started.

By default, the oven prompts the cooling phase to 122°F of the cooking chamber, but it is possible to input the required value starting from a minimum temperature of 86°F.

Upon reaching this temperature, the oven stops cooling and emits an acoustic signal. Once the cooling cycle has started, you can speed the process up manually by inputting water into the chamber. This function is started manually by pressing the button "manual humidifier" **fig.2** for the desired time.

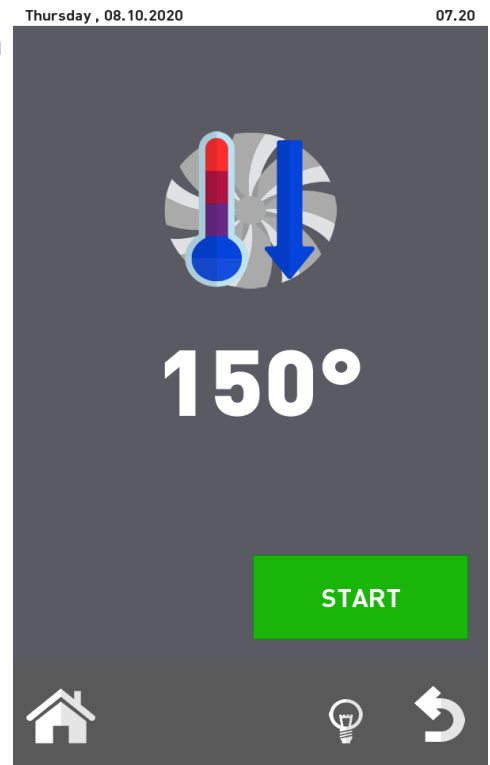

Fig.2



WARNING: Jets of hot air and steam may be released from the cooking chamber! DANGER OF BURNS!!

Service

There are 4 functions in this menu: CONFIGURATION; LOG DISPLAY; ADVANCED SERVICES which allow you to adjust and display a range of functions and start the oven maintenance procedures.

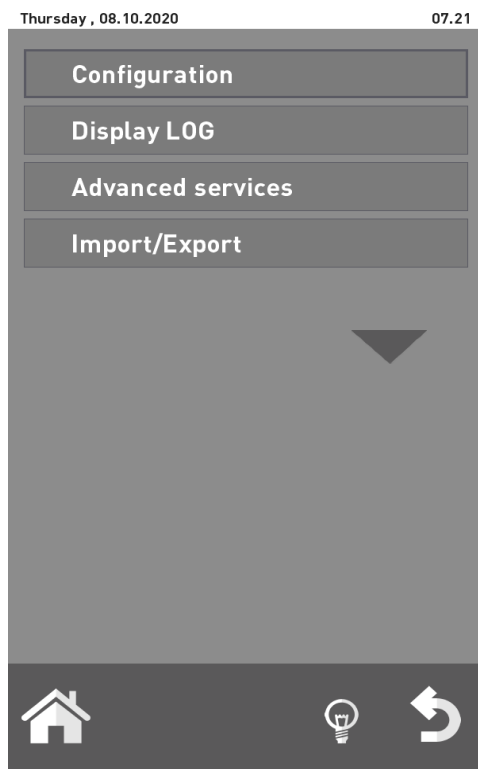

Configuration

A series of parameter configurations can be performed from this menu:

Date and Time

The Date and Time function allows these parameters to be set, by updating them to the current date and time in order to use the oven.

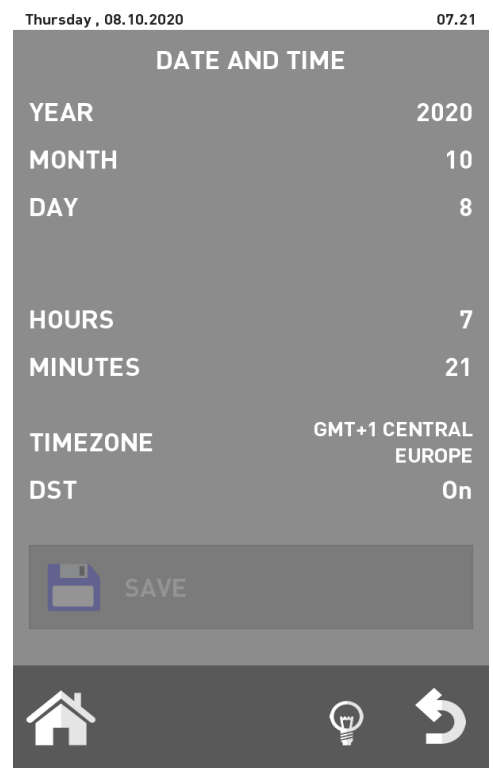

Info System

This function allows you to view the software version installed in the oven and the serial number of the oven.

Language

The language in which the commands and messages are seen on the display can be selected using this function.

Lighting

The Lighting function allows the brightness of the display to be adjusted. Select this function, adjust the brightness using the knob on the control panel and press "Save".

Buzzer volume

This function allows you to adjust the buzzer volume.



3.3.2 LOG DISPLAY

The function proposes the chronological list of the ALARMS LOG and the WASHING LOG.

The first list, ALARMS LOG, displays all of the errors that have been detected and shown on the oven display during its operation.

The second list, WASHES LOG. Displays all of the washes and the type of wash, performed by the oven, also stating the date and start time.

3.3.3 ADVANCED SERVICES

This function is protected by password and allows access to the configuration, setting and inspection functions reserved for the qualified technical staff.

3.3.4 IMPORT/EXPORT

By inserting a USB key, next to the control panel (Fig.9), and accessing the "service" screen from the "home" button, the import and export functions are activated for some of the above-mentioned functions.

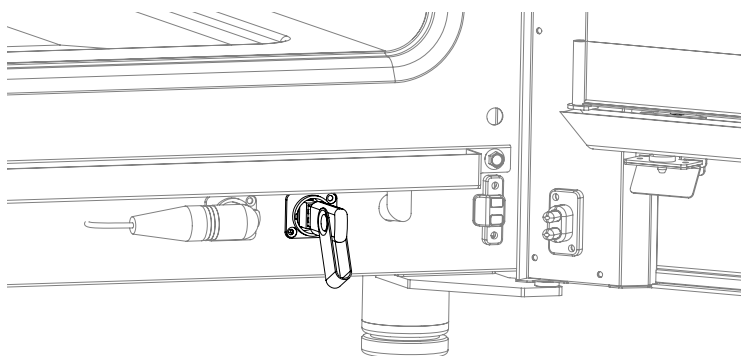

If you insert an EMPTY Sub key, it is possible **TO EXPORT**:

The RECIPE BOOK; HACCP LOGS (this function, when enabled, records the cooking mode and all the relevant data: times, chamber temperature, core probe temperature, the start and all the other phases, etc.) And the WASH LOG.

On connecting a USB key loaded with, for example: new recipes, new parameters or new languages, it is possible **TO IMPORT** this data into the oven software.



MAINTENANCE and CLEANING

Disconnect the appliance from the electric power supply before performing any cleaning or maintenance intervention.

At the end of the working day, clean the appliance, both for reasons of hygiene and to prevent operating faults.

The oven should never be cleaned with direct water or high pressure jets.

Moreover, the appliance should not be cleaned with wire sponges, ordinary steel brushes or scrapers; eventually, you can use stainless steel wool, wiping the appliance in the direction of sheet metal grain.

Wait for the cooking chamber to cool down.

Remove the tray holder panels. Clean the debris that can be removed manually and put the removable parts in the dishwasher. To clean the cooking chamber, use warm soapy water. Subsequently, all concerned surfaces must be rinsed thoroughly and make sure you have removed any detergent residue. To clean the outer parts of the oven, use a damp cloth and a mild detergent.

During the annual inspection, conducted by a qualified technician, remove the deflector and wash it with soapy water.

Cleaning the ventilation filter

In order to keep the electronic components of the oven at a safety temperature, you should clean the ventilation filter periodically, **at least once a month**.

The filter is located on the rear of the oven (**Ref.A - Fig.13**).

Proceed as follows:

1. Grasp the filter tab (**Ref.C-Fig.3**) and lift it so that the filter slides upwards out of its housing.
2. Remove the filter from its mould, wash it with warm water and mild soap and dry it with a clean cloth.
3. Place the filter inside its mould and slide it inside its housing.

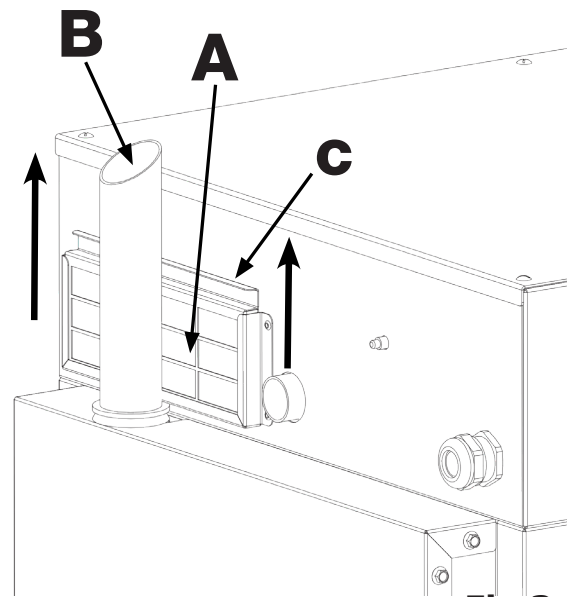

Fig.3

WARNING:

If the oven enters Hi Temp alarm state, the most probable cause is an excessive dirt accumulation on the filter. Therefore, clean the filter immediately.

Installation, Use & Maintenance

Humidity discharge

The humidity discharge (Ref.B Fig.3) expels the steam that forms inside the cooking chamber. Check that it is always perfectly clean and free from obstructions.

Cleaning the Glass

The door glass can be cleaned both on the outside and on the inside. To do this, turn the latch that holds the internal window in position in a clockwise direction (Fig. 4) and, once the window is open, clean it with a suitable detergent. Never use abrasive materials.

The glass should then be closed properly and locked in place by turning the relevant latch.



Fig.4

MANAGEMENT OF SPARE PARTS

The parts should be replaced exclusively by an authorized service center. To identify the codes of spare parts, contact a service representative.

Once the parts required have been identified, the after-sales service will send a written order to the manufacturer, specifying clearly the model of the device, its serial number, the voltage and frequency of power supply, and also the code and a description of the parts concerned.
Only original spare parts must be used for protection of the health of the user and consumer.

Installation, Use & Maintenance

Alarms description

ALARM		DESCRIPTION	ACTION
E01	Chamber probe failure	Cooking chamber temperature detection probe failure	Cooking stopped.
E03	Inverter alarm	Motor control board alarm.	Cooking stopped.
E05	Fan safety	Oven motor thermal safety alarm	Cooking stopped. Automatic reset
E06	Chamber safety	Oven cooking chamber over temperature thermal safety alarm	Cooking stopped. Manual reset by authorized technician
E14	Electronic board temperature alarm	Oven board over temperature alarm	Cooking stopped.
E15	Electronic board temperature pre-alarm	Oven board over temperature pre-alarm	Cooking stopped. Manual reset
E16	No communication with the base	Serial communication problems between the touch board and the base board	Cooking stopped.
E17	Core probe failure	Core probe detection problems	Cooking stopped. Automatic reset
E22	No power.	No external power supply	Cooking stopped. Manual reset

Technical data sheets

Key to technical data sheets

- A** Electrical power supply
- B** Input for softened water (GHT 3/4)
- C** Equipotential connection
- D** Oven drain (Ø 1.5")
- E** Humidity discharge (Ø 1.5")
- F** Detergent tube inlet

Installation, Use & Maintenance

061 (W)

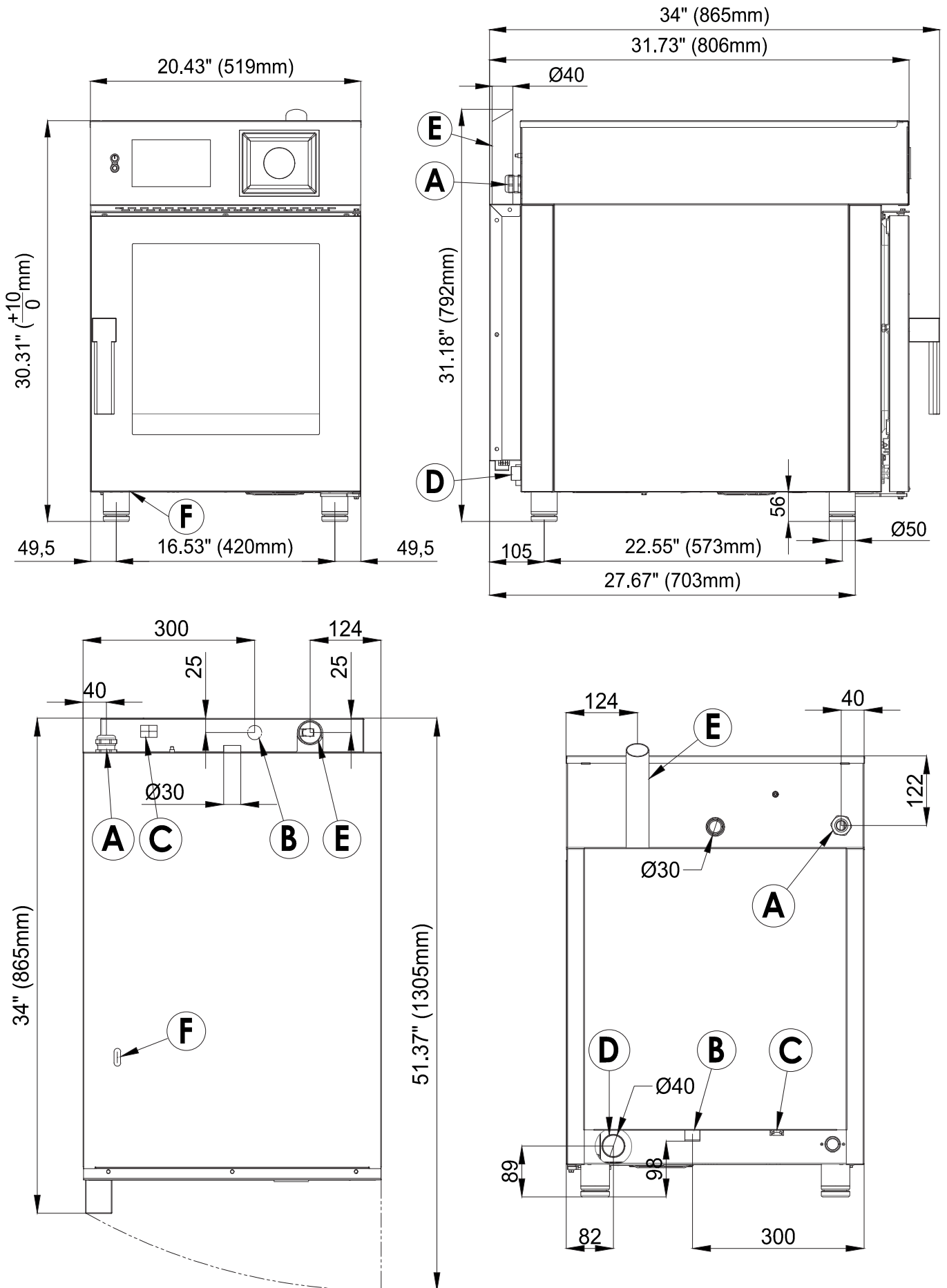

Installation, Use & Maintenance

101 (W)

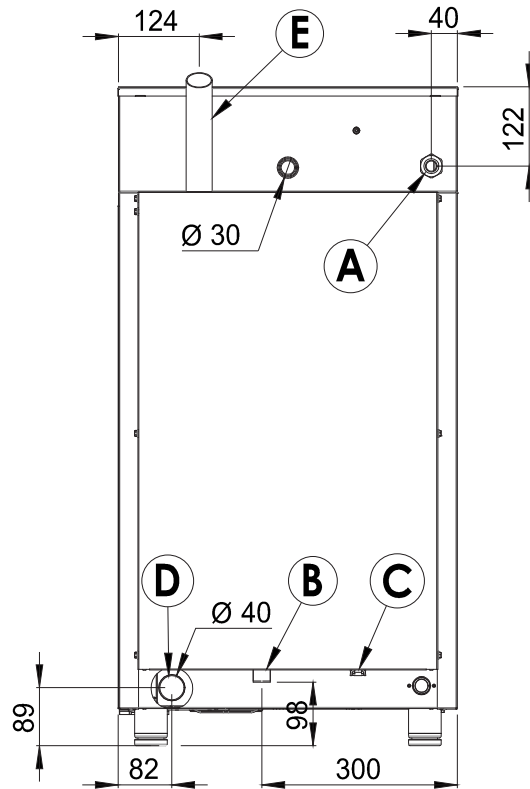
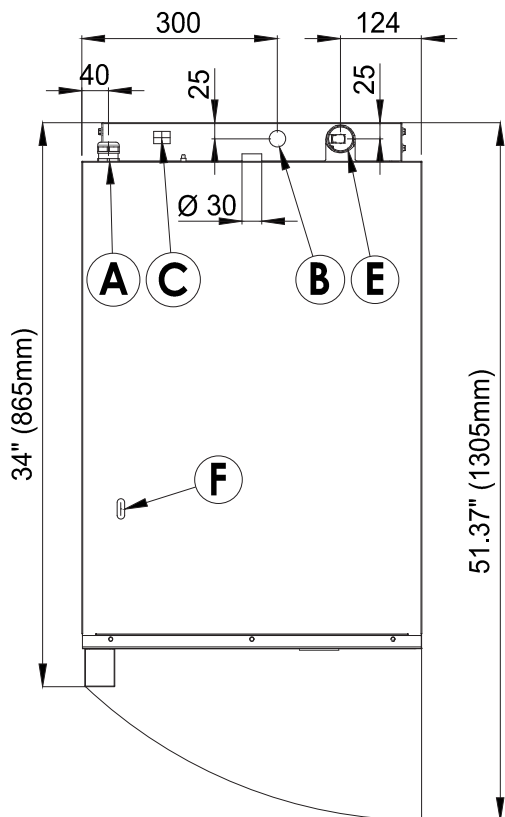
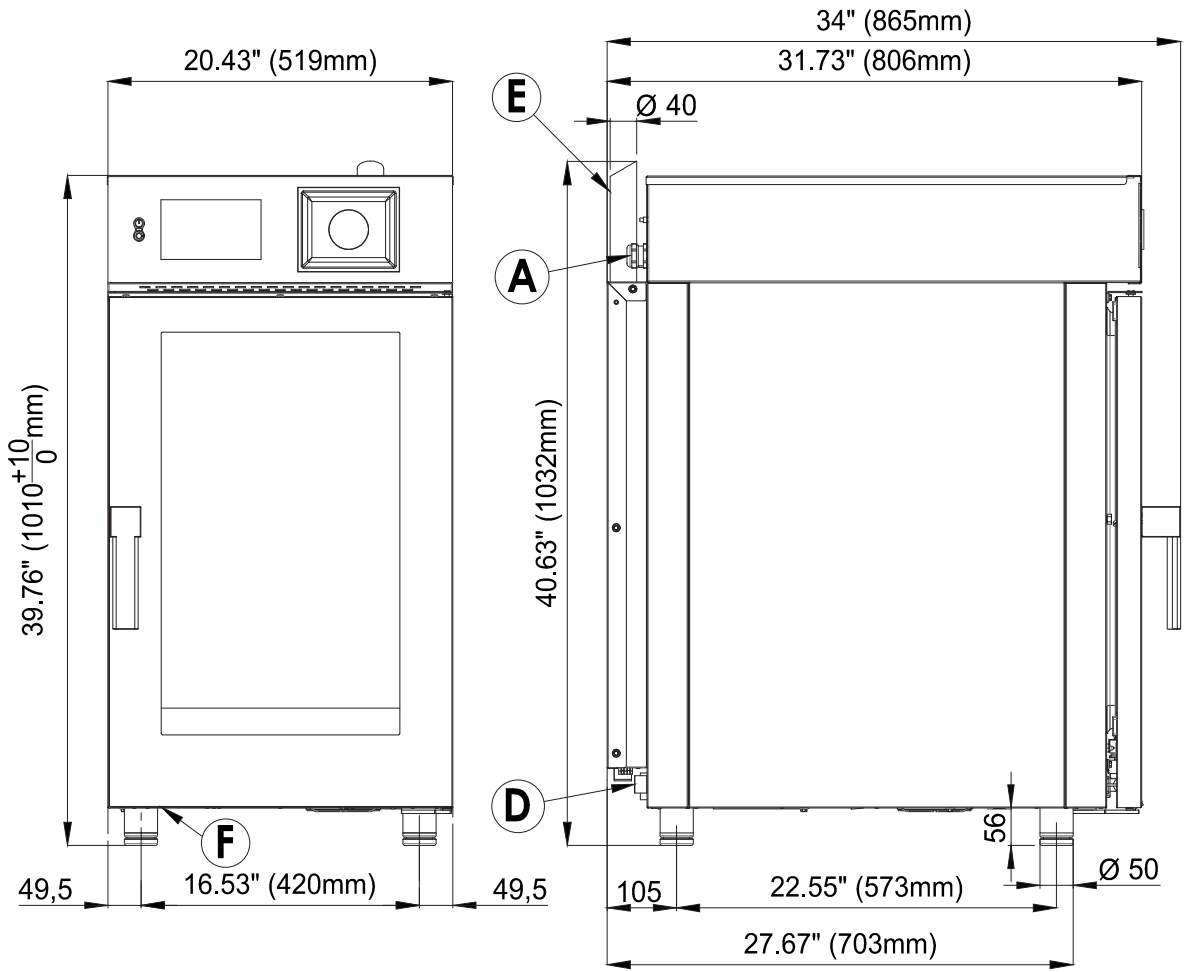



THE MANUFACTURER SHALL NOT BE HELD LIABLE FOR ANY DAMAGES DUE TO IMPROPER INSTALLATION, TAMPERING WITH THE APPLIANCE, MISUSE, IMPROPER MAINTENANCE, FAILURE TO COMPLY WITH APPLICABLE STANDARDS AND INTENDED USE. THE MANUFACTURER RESERVES THE RIGHT TO MAKE CHANGES TO THE PRODUCT AT ANY TIME IT DEEMS NECESSARY OR USEFUL.